

Contents

Preface	1
Introduction	1
The Owner's Handbook	1
User Privacy Policy	1
Status at Time of Printing	1
Symbols Used	2
Vehicle Identification Information	3
Vehicle Identification	3
Vehicle Identification Label	4
Instructions for Use of Electric Vehicle	6
Effects of Ambient Temperature	6
Instructions for High Voltage Battery Pack Recycling	6
Driving Range	7
Equalisation Charging	8
Intelligent Charging	8
Crash Outage Control	9
High Voltage System	9
Precautions in the Event of an Accident	12
1 Instruments and Controls	13

Instruments and Controls	14
Instrument Pack	16
Instrument Pack Operation Buttons	16
Display Information.....	17
Warning Message.....	20
Warning Lights and Indicators	28
Lights and Switches	39
Master Light Switch.....	39
Headlamp Leveling Manual Adjustment	40
Direction Indicator/Main Beam Switch.....	41
Smart Main Beam System	43
Rear Fog Lamps	44
Hazard Warning Lamps	45
Wipers and Washers	46
Front Windscreen Wiper Controls	46
Rear Windscreen Wiper Controls	48
Steering System	50
Adjustment of Steering Column.....	50
Electric Power Steering	50

Horn	52
Mirrors	53
Exterior Rearview Mirrors	53
Interior Rearview Mirror	56
Sunvisor	58
Windows	59
Power Operated Window Switch	60
Window Operation	60
Sunroof	63
Instructions	63
Sunroof Operation	64
Interior Light	68
Front Interior Lamp	68
Rear Interior Lamp	68
Automatic Operation	69
Ambient Lighting *	69
Power Socket	70
Front Console Power Socket	70
Rear Console USB Charging Ports	71

Wireless Charging System for Mobile Phones *	72
Wireless Charging of Mobile Phones	72
Storage Devices	74
Instructions	74
Glove Box	74
Centre Console Front Storage Box	75
Centre Console Armrest Box	75
Cup Holder	76
Centre Console Cup Holder	76
Rear Armrest and Rear Cup Holder	76
Roof Luggage Rack	77
Maximum Authorised Load for the Roof.....	77
Periodical Check.....	77
2 Air Conditioning and Audio Systems	79
Ventilation	80
A/C Filter.....	81
Centre Console Vents.....	81
Automatic Temperature Control	82

Control Interface.....	82
Auto Mode.....	83
Cooling On/Off	83
Air Recirculation Mode	83
Temperature Zone Control	84
Economy Mode.....	84
Air Distribution Mode.....	84
Intelligent Electric Sweeping Vent Control	85
Temperature Control	86
System On/Off	86
Blower Speed Control.....	86
Defrost/Demist.....	86
Heated Rear Window	87

3 Seats & Restraints.....89

Seats.....	90
Overview	90
Head Restraints	90
Front Seats.....	91
Rear Seats	92

Seat Ventilation Function *	92
Seat Heating Function	93
Driver's Seat Personalisation Function	94
Driver Seat Welcome Function	94
Seat Memory Function	94
Seat Belts	96
Protection Provided by Seat Belts	96
Wearing Seat Belts	98
Children and Seat Belts	103
Seat Belt Pre-tensioners	104
Seat Belt Checks, Maintenance and Replacement	105
Airbag Supplementary Restraint System	107
Overview	107
Airbag Deployment	108
Conditions in Which Airbags Will Not Deploy	111
Disabling the Passenger Airbag	112
Service and Replacement of Airbags	113
Disposal of Airbags	114
Child Restraints	116

Important Safety Instructions about Using Child Restraints	116
How to Fasten a Child Restraint	119
Approved Child Restraint Groups and Positions	122
4 Starting & Driving	127
Keys	128
Overview	128
Replacing the Battery	129
Child Proof Locks	131
Alarm Systems	132
Power Immobilisation	132
Body Anti-theft System	132
Electric Tailgate	136
Starting and Stopping Power System	140
START/STOP Switch	140
READY Mode	141
Switching the Power System OFF	143
Pedestrian Alert Control System	144
Economical and Environmental Driving	145

Running-in.....	145
Economic Driving and Maintenance.....	145
Driving in Special Environment.....	146
Charging and Discharging Requirements.....	147
Charging Your Vehicle at Home.....	149
Installed Charging Points.....	149
Home Charging Guide.....	149
Charging and Medical Condition Awareness.....	150
Charging Port.....	150
Rapid Charging.....	153
Slow Charging.....	153
Charging Information.....	156
Equalisation Charging.....	157
Charging Times.....	157
Discharging.....	161
Electric Drive Transmission.....	163
Instructions.....	163
Gear Shift Control.....	163
Vehicle Start-off.....	166

Driving on Hills.....	167
Driving Mode - 2WD *	167
Driving Mode - AWD *	169
Energy Regeneration (REGEN)	173
Protection Mode.....	174
Brake System.....	177
Foot Brake	177
Electronic Hydraulic Brake Application System (EHBS)	177
Hydraulic Booster Compensation System (HBC)	178
Cooperative Regenerative Braking System (CRBS)	178
Electronic Brake Force Distribution (EBD).....	179
Electronic Brake Assistance (EBA).....	179
Hill Hold Control (HHC)	179
Auto Hold.....	181
Hill Descent Control System (HDC)	183
Anti-lock Brake System (ABS).....	185
Emergency Braking Hazard Warning Lights Control System (HAZ).....	186
Multi-Collision Brake System (MCB).....	187
Electronic Parking Brake (EPB).....	188

Stability Control System (SCS) and Traction Control System (TCS)	191
Driver Attention Warning System	192
Adaptive Cruise Control System	194
Adaptive Cruise Control System Activation	194
Adaptive Cruise Target Speed Adjustment	196
Adaptive Cruise Target Following Distance Adjustment	197
Adaptive Cruise Pause/Standby	198
Automatic Deactivation of Adaptive Cruise	198
Adaptive Cruise Override	198
Adaptive Cruise Resume	198
Clear Speed Memory	199
Adaptive Cruise Control System Impairment and Ineffectiveness	199
Special Driving Environments	199
Parking Aid System	203
Ultrasonic Sensor Parking Aid.....	203
360 Around View System *	205
Rear Driving Assistance System	206
System Overview	206
Switching the System Functions On/Off	207

System Functions	208
Tyre Pressure Monitoring System (TPMS)	213
Driving Assist System	214
Description of Front View Camera	214
Description of Front Detection Radar	215
Speed Assist System	216
Lane Assist System	221
Traffic Jam Assist System	223
Forward Collision System	226
Load Carrying.....	230
Loadspace Loading.....	230
Internal Loading.....	231
General Towing Safety.....	231
5 Emergency Information	233
Hazard Warning Devices	234
Warning Triangle.....	234
eCall - SOS Emergency Assistance	235
Emergency Starting	237

Vehicle Recovery	240
Towing for Recovery	240
Transporter or Trailer with Rope	244
Tyre Repair	245
Tool Identification	245
Tyre Repair	245
Changing a Wheel *	248
Fuse Replacement	252
Fuse	252
Fuse Box	252
Bulb Replacement	260
Bulb Specification	260
Bulb Replacement	260
6 Maintenance	263
Maintenance	264
Routine Servicing	264
Bonnet	267
Opening the Bonnet	267

Closing the Bonnet	267
Bonnet Open Warning	267
Front Compartment	269
2WD	269
AWD	270
Cooling System	271
Coolant Check and Top Up - EDS	271
Coolant Check and Top Up - ESS	272
Coolant Specification	272
Brake	273
Brake Pads	273
Brake Fluid Check and Top Up	273
Brake Fluid Specification	274
Battery	275
Battery Maintenance	275
Battery Replacement	276
High Voltage Battery Pack.....	277
Precautions and restricted conditions for use of battery	277
Washer	279

Washer Fluid Check and Top Up.....	279
Washer Nozzles	280
Wipers	281
Wiper Blades.....	281
Replacing Front Windscreen Wiper Blades	282
Replacing Rear Window Wiper Blades	283
Tyre	284
Overview	284
Caring for your Tyres	286
Tyre Wear Indicators	286
Replacement of Tyres.....	287
Tyre Rotation	287
Tyre/Snow Chains	289
Cleaning and Vehicle Care.....	290
Exterior	290
Cleaning the Interior.....	293
7 Technical Data.....	295
Technical Data Dimensions	296

Weights	298
Towing Weights	299
Parameters of Traction Motor	300
Recommended Fluids and Capacities	301
Wheel Alignment (Unladen)	302
Wheels and Tyres	302
Tyre Pressure (Cold)	302

Preface

Introduction

The Owner's Handbook

This handbook describes all of the vehicles and standard equipment specification within the model range. Some of the information, therefore, may not apply to your particular car.

Always remember that if you have any queries concerning the operation or specification of your car, your MG Authorised Repairer will be glad to advise you.

The illustrations in the Owner's Handbook are for reference only.

The information presented in this manual may vary slightly depending on vehicle configuration, software version and sales area.

User Privacy Policy

Your personal information privacy is greatly respected, any collection of this information will only be done with your permission.

Any collected customer information will be used to provide you with a higher quality and more accurate personalized

service. We promise to use your personal data only in accordance with legal conditions. In order to ensure the security of your personal data, we will implement strict privacy protection measures.

For more information on this policy, please contact your MG Authorised Dealer. Please refer to the Privacy Policy and the privacy settings in the entertainment system for relevant statements.

Status at Time of Printing

MG operates a policy of constant product improvement and therefore reserves the right to change specifications without notice at any time. Whilst every effort is made to ensure complete accuracy of the information in this publication, no liabilities for inaccuracies or the consequences thereof, including loss or damage to property, or injury to persons, can be accepted by the manufacturer or the MG Authorised Repairer who supplied the publication, except in respect of personal injury caused by the negligence of the manufacturer or the MG Authorised Repairer .

Preface

Symbols Used

The following symbols used within the handbook call your attention to specific types of information.

Warning



This warning symbol identifies procedures that must be followed precisely, or information that must be considered with great care, in order to reduce the risk of personal injury or serious damage to the car.

Important

IMPORTANT

The statements stated here must be followed strictly, otherwise your car could be damaged.

Note

Note: This describes helpful information.



This symbol indicates that parts described must be disposed of by authorised persons or bodies to protect the environment.

Asterisk

An asterisk (*) appearing within the text identifies features or items of equipment that are either optional, or that only some vehicles in the model range are equipped with.

Illustration Information



Identifies components being explained.



Identifies movement of components being explained.

Vehicle Identification Information

Vehicle Identification

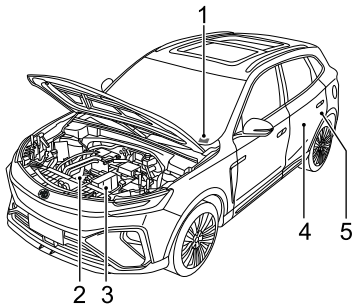

- 1 Vehicle Identification Number (VIN)
- 2 Drive Motor Number - 4WD
- 3 Electric Drive Transmission Number - 4WD
- 4 Drive Motor Number
- 5 Electric Drive Transmission Number

Always quote the Vehicle Identification Number (VIN) when communicating with an MG Authorised Repairer. If the drive motor or electric drive transmission is involved, it may be required to provide the identification numbers of these assemblies.

Vehicle Identification Location

Vehicle Identification Number (VIN)

- On the floor under the driver's seat;
- On the identification plate;
- Stamped on a plate visible through the bottom left hand corner of the windscreen;
- On the inner side of the tailgate; visible by opening the tailgate.

Note: *The DLC is located in the driver footwell at the base of the fascia panel on the RH side. The VIN information can be extracted from the vehicle using the approved diagnostic equipment.*

Drive Motor Number

Stamped on the lower part of the drive motor housing.

Electric Drive Transmission Number

Preface

Stamped on the upper part of the electric drive transmission housing.

Vehicle Identification Label

The Vehicle Identification Label contains the following information:

- Type Approval Number
- Vehicle Identification Number (VIN)
- Gross Vehicle Weight *
- Gross Train Weight *
- Max Front Axle Weight *
- Max Rear Axle Weight *
- Model
- Engine Type
- Date of Production
- Country

Location of Vehicle Identification Label

The Vehicle Identification Label is located at the lower side of right side B pillar.

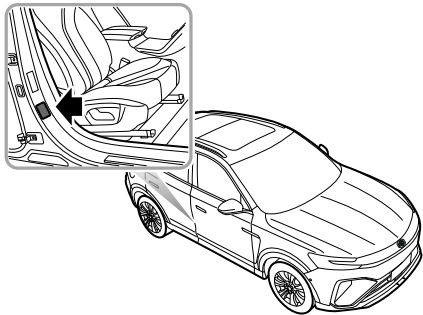

Instructions for Use of Electric Vehicle

Effects of Ambient Temperature

The working performance of the high-voltage battery pack fitted to your vehicle is related to the ambient temperature. This battery powers the vehicle power system and therefore it is recommended that where possible the vehicle should be used within the temperature range of -15 to 45°C. This will ensure that the vehicle is in the optimum working state, and help extend the service life of the high-voltage battery pack. Extremely high or low temperatures will affect the performance of the high-voltage battery pack and vehicle.

Instructions for High Voltage Battery Pack Recycling

The high-voltage battery pack fitted to your vehicle contains several lithium based battery cells. It is installed centrally to the motor-vehicle chassis. Arbitrary disposal may cause pollution, hazard and damage to the environment. The high-voltage battery pack **MUST** be recycled by an MG Authorised Repairer or a professional

approved dismantling agent. Please refer to the following information and requirements.

- **ONLY** qualified personnel should work with the high voltage system - there is danger of DEATH.
- High voltage safety: the high voltage system fitted to your vehicle features a HV battery containing high voltage components such as lithium battery packs and high voltage wiring harness; **DO NOT** attempt to dismantle any area of this system, suitably trained professional staff must observe insulation safety protection before working on or near the high voltage system.
- Transportation: The high-voltage battery pack is classed as a Category 9 hazardous material and must be transported by vehicles qualified in transporting Category 9 hazardous materials.
- Storage: All HV components (including batteries) should be stored at room temperature and in a dry environment. They must be kept away from dangerous sources, such as flammable objects, heat and water sources.

Preface

- Internal composition: The high-voltage battery pack consists of lithium batteries (pack), PCB, HV and normal electric wiring, metal casing and other components.

It is strongly recommended that the used high-voltage battery pack generated from vehicle scrappage or any other reasons should be disposed of by an MG Authorised Repairer.

Note: If you decide not to use the recommended MG Authorised Repairer to dispose of your high voltage battery, the responsibility of the consequences of environmental pollution or accidents must be borne by the owner.

Driving Range

The driving range of your vehicle depends on the HV battery condition, quantity of available electricity, vehicle age (current remaining battery life), weather, temperature, road conditions and driving habit etc.

The range can be affected by other electrical loads (such as A/C, lights etc), driving style and general road conditions.

It should be noted that:

- The driving range is related to the rate of discharge. In order to avoid a high rate of discharge from affecting the performance of the high-voltage battery pack, it is recommended that the vehicle is connected to a suitable charger upon illumination of the low battery warning lamp in the instrument pack.
- The actual driving range of the vehicle will reduce with the increase of vehicle age.
- The use of A/C will reduce the driving range.
- The driving range varies at different speeds.
- At low temperatures, the driving range will be reduced due to temperature characteristics of the battery during use.
- In some instances of extreme temperatures and low battery voltage, you may experience insufficient acceleration or power reduction. This is due to battery characteristics.

To help increase the range of the vehicle please observe the following:

- Have the vehicle regularly maintained as per service schedule.
- Always ensure the tyre pressures are correct.

Preface

- Try and use the vehicle between the recommended ambient temperatures.
- Do not park or store the vehicle for long periods with a low state of charge, where possible charge the vehicle as soon as possible prior to storage.
- Remove unnecessary articles to reduce the vehicle load.
- Use of high power consuming systems such as A/C and heating will use large amounts of power. This will reduce the driving range.
- At a high speed, where possible, close the windows to reduce wind resistance and power consumption.
- Try to maintain a steady speed at all times, avoid constant acceleration and braking.
- During acceleration, apply the accelerator pedal as gently as possible.
- During deceleration, release the accelerator pedal; under certain conditions when not applying the brake or gently applying the brake, the energy regeneration system (KERS) will assist in charging the HV battery and extend the driving range.

Equalisation Charging

In order to assist in extending the service life of the high voltage battery pack it is recommended that an equalisation charge is carried out at regular intervals.

Please see "Equalisation Charging" in the "Starting & Driving" section.

Intelligent Charging

The 12V battery SOC is constantly monitored, when the Start/Stop switch is in the OFF position it is possible, under certain conditions, that the HV battery will automatically charge the 12V battery to ensure the vehicle starts. This function will activate and switch off automatically.

Note: The system will suspend intelligent charging if a fault is present, when starting or the vehicle is being charged by an external device.

Note: The driving range will be reduced after intelligent charging.

Note: The intelligent charging function is suspended when the high voltage battery is in a low SOC.

Preface

Crash Outage Control

If a crash or serious impact occurs, a signal from the SDM (Airbag Control Module) will disconnect the relays within the battery management system isolating the high voltage battery from the systems on the vehicle.

High Voltage System



- *The high voltage system used on your vehicle features AC and DC voltages up to about 417V. All high voltage components have warning labels attached - please observe these warnings and any requirements when operating within or close to these areas.*
- *ONLY qualified personnel should work on, or with, the high voltage system - there is danger of DEATH.*

Preface

The high voltage system component layout (2WD) is shown below:

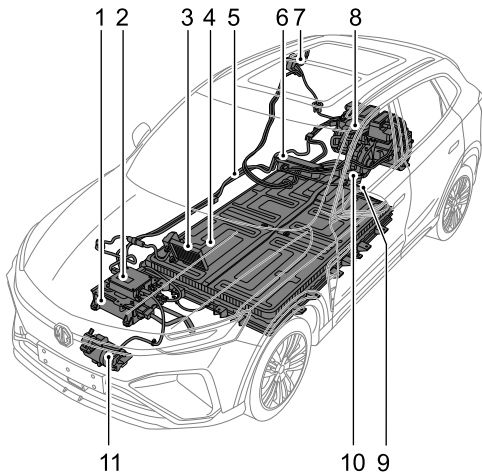

- 1 Combined Charging Unit (CCU)
- 2 Front Power Distribution Unit (PDU)
- 3 Electric Heater
- 4 High Voltage Battery (ESS)
- 5 High Voltage Harness
- 6 Rear Power Distribution Unit (PDU)
- 7 Charging Port
- 8 Electric Drive Transmission
- 9 Manual Service Disconnect (MSD)
- 10 HV Battery Heater
- 11 Electric A/C Compressor

Preface

The high voltage system component layout (4WD) is shown below:

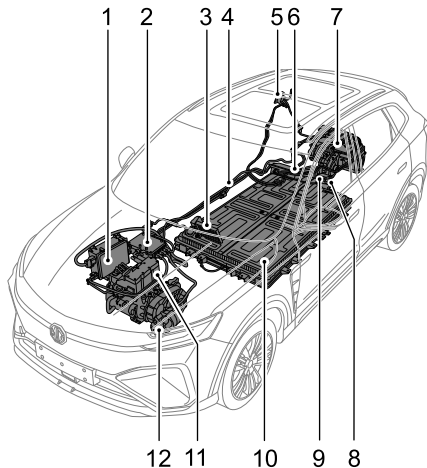

- 1 Combined Charging Unit (CCU)
- 2 Front Power Distribution Unit (PDU)
- 3 Electric Heater
- 4 High Voltage Harness
- 5 Charging Port
- 6 Rear Power Distribution Unit (PDU)
- 7 Rear Electric Drive Transmission
- 8 Manual Service Disconnect (MSD)
- 9 HV Battery Heater
- 10 High Voltage Battery (ESS)
- 11 Front Electric Drive Transmission
- 12 Electric A/C Compressor

Precautions in the Event of an Accident



- *Ensure the vehicle is in P, the parking brake is applied and the vehicle power system is OFF.*
- *If any cables on the vehicle are exposed, in order to prevent electric shock or even death DO NOT make any contact with any cable.*
- *If the vehicle catches fire, and the fire is small and slow, a carbon dioxide extinguisher can be used to extinguish the fire, and contact the fire services as soon as possible; if the fire is large and spreading quickly, immediately evacuate the vehicle and contact the fire services immediately.*
- *If the vehicle is involved in a collision and cannot be re-started, the negative cable of 12V battery and Manual Service Disconnect (MSD) MUST be disconnected prior to rescue.*
- *When the vehicle is completely or partially immersed in water, switch off the vehicle power system and evacuate the car immediately. The negative cable of 12V battery and Manual Service Disconnect (MSD) MUST be disconnected prior to rescue or as soon as the vehicle is refloated/removed from the water. Observe the water/vehicle for any abnormal signs such as excessive bubbles or noises, this may indicate battery short circuit issues. If no signs are evident, there should not be a shock risk from the bodywork and recovery can commence.*
- *If your car is being recovered by an independent recovery agent, please contact an MG Authorised Repairer for guidance.*
- *The vehicle is supplied with an emergency response information card. Please show the card to the rescue personnel when they arrive.*

Instruments and Controls

- | | | | |
|----|--------------------------------------|----|---|
| 14 | <i>Instruments and Controls</i> | 72 | <i>Wireless Charging System for Mobile Phones *</i> |
| 16 | <i>Instrument Pack</i> | 74 | <i>Storage Devices</i> |
| 28 | <i>Warning Lights and Indicators</i> | 76 | <i>Cup Holder</i> |
| 39 | <i>Lights and Switches</i> | 77 | <i>Roof Luggage Rack</i> |
| 46 | <i>Wipers and Washers</i> | | |
| 50 | <i>Steering System</i> | | |
| 52 | <i>Horn</i> | | |
| 53 | <i>Mirrors</i> | | |
| 58 | <i>Sunvisor</i> | | |
| 59 | <i>Windows</i> | | |
| 63 | <i>Sunroof</i> | | |
| 68 | <i>Interior Light</i> | | |
| 70 | <i>Power Socket</i> | | |
-

Instruments and Controls

Instruments and Controls

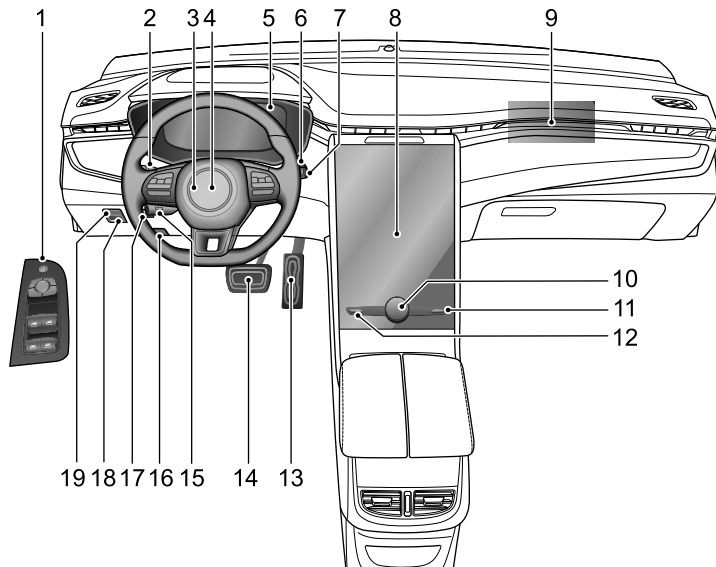

Instruments and Controls

- 1 Exterior Rearview Mirrors and Power Window Switch
- 2 Indicator and Main Beam Stalk Switch
- 3 Horn Button
- 4 Driver Airbag
- 5 Instrument Pack
- 6 START/STOP Switch
- 7 Wiper/Washer Control
- 8 Onboard Entertainment System
- 9 Front Passenger Airbag
- 10 Shift Control Knob
- 11 Energy Regeneration (REGEN) Selection Switch
- 12 Driving Mode Selection Switch
- 13 Accelerator Pedal
- 14 Brake Pedal
- 15 Cruise Control Stalk Switch (Back of Steering Wheel)
- 16 Bonnet Release Handle
- 17 Headlamp Levelling Adjustment Switch
- 18 EPB Switch
- 19 Auto Hold Switch

Instruments and Controls

Instrument Pack

Instrument Pack Operation Buttons

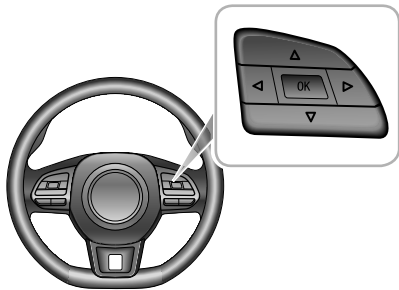

The instrument pack operation buttons are located in the RH steering wheel multifunction switch pack.

When the vehicle power system is in the ON/READY position, press the ◀ or ▶ arrows to cycle between the display area. When the selected display area is highlighted, you can operate the buttons to switch or adjust the display items:

- Press the ▲ or ▼ arrows to cycle through the items that can be displayed.
- Press the OK button to confirm or long press it to reset.
- Press the ◀ button on the sub-menu interface to return to the previous menu.

Instruments and Controls

Display Information

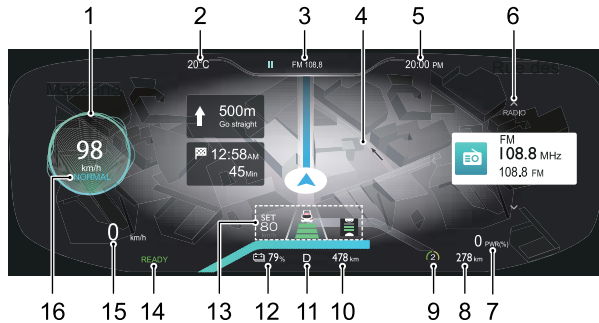

Instruments and Controls

I Vehicle Information

Vehicle Information is located in the left area of the instrument pack. When the left area is highlighted, press the Δ or ∇ button to cycle through the following display items:

- Speedometer: Indicates the vehicle speed in km/h.
- Active Safety : Displays the active safety information of the vehicle.
- TPMS Monitor: displays the current tyre pressure status of the vehicle.
- Current Journey: displays the trip time, trip distance, average speed and average energy since the last vehicle start.
- Accumulated Total: displays the trip time, trip distance, average speed and average energy since the last vehicle reset.
- Warning Information Centre: displays any current failure messages or important prompt messages of the vehicle.
- Setting: sets the luminance level and the overspeed threshold.

- Power Centre: displays the power meter, electric transient consumption, electric information (voltmeter, ammeter, motor speed), energy flow .

2 Ambient Temperature

3 Status Bar

Attention should be paid to the warning message displayed here.

4 Map/Navigation

Displays the map/navigation information from the centre console entertainment system.

5 Time

6 Infotainment

Infotainment information is located in the right area of the instrument pack, When the right area is highlighted, press the Δ or ∇ button to switch between Bluetooth phone and music information from the centre console entertainment system.

7 Power Meter

When the vehicle information area is not switched to the power meter, the power information will be displayed here.

If the power is displayed as a positive value, it represents that the power system outputs power to drive the vehicle; If the power is displayed as a negative value, it represents that the power system converts part of the kinetic energy into electrical energy.

8 Odometer

9 Energy Regeneration Level Indication

Displays the current energy regeneration level of the vehicle. For more information, refer to "Energy Regeneration (REGEN)" in "Starting & Driving" section.

10 Range to Empty

Displays the estimated remaining distance you can travel before the high-voltage battery pack runs out.

11 Gear Display

Displays the current gear position. For more information, refer to "Electric Drive Transmission" in "Starting & Driving" section.

12 Electricity Meter of High-voltage Battery Pack

IMPORTANT

- Charge the high-voltage battery pack as soon as possible when the battery is low.
- Ensure the high-voltage battery pack is storing enough power before driving.

13 Active Safety

Displays the active safety information of the vehicle.

For more information, please refer to "Adaptive Cruise Control System" and "Driving Assist System" in "Starting & Driving" section.

14 Power System Status

Displays the current status of the power system. READY indicates that the vehicle power system is ready for driving. POWER OFF indicates that the vehicle power system is Off.

Instruments and Controls

15 Speedometer

When the vehicle information area is not switched to the speedometer, the speed information will be displayed here.

16 Driving Mode

Displays the current driving mode of the vehicle. For more information, refer to "Driving Mode - 2WD" and "Driving Mode - AWD" in "Starting & Driving" section.

Warning Message

Warning messages and prompts are displayed in the instrument pack. Any communications are displayed in 'pop up' messages. These can be divided into the following categories:

- Operation Instruction
- System State Instruction
- System Malfunction Alert

Please follow the instructions displayed in the 'pop up' message or in the case of a warning message, please refer to the relevant section of the owners manual to follow the correct instructions.

The following are a selection of warning messages that may appear in the information message centre.

Warning Message	Action
Cruise Control Fail	Indicates that the cruise control system has detected a fault. Please contact an MG Authorised Repairer as soon as possible.
Ignition System Fault Please Repair	Indicates that the power mode has detected a fault. Please contact an MG Authorised Repairer immediately.
Start/Stop Button Fault	Indicates that the START/STOP Switch has detected a fault. Please contact an MG Authorised Repairer immediately.
Passive Entry Fault Please Repair	Indicates that the passive keyless entry function has detected a fault. Please contact an MG Authorised Repairer as soon as possible.

Instruments and Controls

1

Warning Message	Action
ABS Fault	Indicates that the anti-lock brake system (ABS) has detected a fault, and the ABS function is about to be disabled. Please contact an MG Authorised Repairer immediately.
Brake Fault	Indicates that a fault has been detected within the braking system. Stop the vehicle as soon as safety permits, switch the vehicle power system OFF, check the brake fluid level and contact an MG Authorised Repairer immediately.
Stability Control Fault	Indicates that the SCS system has detected a fault. Please contact an MG Authorised Repairer immediately.

Warning Message	Action
Traction Control Fault	Indicates that the TCS system has detected a fault. Please contact an MG Authorised Repairer immediately.
Hill Descent Control Fail	Indicates that the HDC system has detected a fault. Please contact an MG Authorised Repairer as soon as possible.
EPB System Fault	Indicates that the EPB system has detected a fault. Please contact an MG Authorised Repairer as soon as possible.
Park Brake Force Not Enough	Indicates that the electronic parking brake system has detected a fault when parking. Please contact an MG Authorised Repairer as soon as possible.

Instruments and Controls

Warning Message	Action
Autohold Fail	Indicates that the auto hold function has detected a fault. Please contact an MG Authorised Repairer as soon as possible.
EPS Performance Decrease	Indicates that the electric power steering system (EPS) has a general failure and the performance is reduced. As soon as conditions permit, safely stop the vehicle and switch the vehicle power system to the OFF position. After a short while, switch the vehicle power system to the READY position, drive the vehicle a short distance and monitor the operation of the steering. If the message is still displayed or the steering assistance reduced, please contact an MG Authorised Repairer immediately.

Warning Message	Action
Power Steering Fault Please Repair	Indicates that the electric power steering system (EPS) has detected a fault. Please contact an MG Authorised Repairer immediately.
Steering Angle Fault Please Repair	Indicates that the steering angle sensor has failed. Please contact an MG Authorised Repairer as soon as possible.
Steering Angle Uncalibrated	Indicates that the steering angle sensor is not calibrated. Please contact an MG Authorised Repairer as soon as possible.
iBooster System Fault	Please slow down, stop the vehicle as soon as safety permits and contact an MG Authorised Repairer immediately.

Instruments and Controls

Warning Message	Action
iBooster Braking Ability Fault	Please stop the vehicle as soon as safety permits, turn off the START/STOP Switch and contact an MG Authorised Repairer immediately.
PDC System Fault	Indicates that PDC system has detected a fault. Please contact an MG Authorised Repairer as soon as possible.
Airbag Fault Please Repair	Indicates that the SDM has detected a fault. As soon as conditions permit, safely stop the vehicle and switch the vehicle power system to the OFF position and contact an MG Authorised Repairer immediately.
TPMS Fault	Indicates that the tyre pressure monitoring system (TPMS) has detected a fault. Please contact an MG Authorised Repairer as soon as possible.

Warning Message	Action
Front Left/Front Right/Rear Left/Rear Right Tyre Sensor Battery Low	Indicates that the TPMS has detected a sensor has a low battery. Please contact an MG Authorised Repairer as soon as possible.
Pedestrian Alert System Fault	Indicates that the pedestrian alert system has detected a fault. Please contact an MG Authorised Repairer as soon as possible.
Power Tailgate System Fault	Indicates that the power tailgate system has detected a fault. Please contact an MG Authorised Repairer as soon as possible.
Unsteady Driving Warning system failed	Indicates that the driver attention warning system has detected a fault. Please contact an MG Authorised Repairer as soon as possible.

Instruments and Controls

Warning Message	Action
4WD System Fault	Indicates that the 4WD system has detected a fault. Please contact an MG Authorised Repairer immediately.
DCDC Charge Fault	Indicates that the CCU has detected a fault. Please contact an MG Authorised Repairer immediately.
12V Battery Charging System Fault	Indicates that the 12V battery charging system has detected a fault. Please contact an MG Authorised Repairer immediately.
12V Battery Maintenance Required	Please contact an MG Authorised Repairer immediately.
HV Battery Fault	Indicates that the HV battery has detected a fault. Please contact an MG Authorised Repairer immediately.

Warning Message	Action
Get out of the vehicle immediately	As soon as conditions permit, safely stop the vehicle and evacuate all occupants immediately, and contact an MG Authorised Repairer immediately.
System Fault	Indicates that the power system has detected a fault. Please contact an MG Authorised Repairer as soon as possible.
Motor Overheating	Indicates that the motor has overheated. Please contact an MG Authorised Repairer as soon as possible.
EDU Coolant Overheating	Indicates that the EDS coolant has overheated. Please contact an MG Authorised Repairer as soon as possible.

Instruments and Controls

Warning Message	Action
Motor Fault	Indicates that the drive motor has detected a fault. As soon as conditions permit, safely stop the vehicle and switch the vehicle power system to the OFF position and contact an MG Authorised Repairer immediately.
Gearbox fault Reversing gear is not supported	Please contact an MG Authorised Repairer immediately.
Compressor High Voltage Fault	Please contact an MG Authorised Repairer immediately.
ecall System Fault	Indicates to the driver via a yellow SOS warning lamp that the ecall system has detected a fault and is not operating within its parameters. The SOS button LED status indicator flashes twice per second. Please contact an MG Authorised Repairer as soon as possible.

Warning Message	Action
ecall System Failure	Indicates to the driver via a red SOS warning lamp that the ecall system has failed and is not capable of supporting in the event of an accident. The SOS button LED status indicator is not illuminated. Please contact an MG Authorised Repairer immediately.
ecall in Progress	Indicates to the driver via a green SOS warning lamp that an emergency services call is currently in progress. The SOS button LED status indicator flashes once per second.
ecall System Disabled	Indicates to the driver via a red SOS warning lamp that automatic ecall service is disabled. Please contact an MG Authorised Repairer to reactivate the automatic ecall function.

Instruments and Controls

Warning Message	Action
Rear Drive Assist System Fault	Indicates that the rear drive assist system (RDA) has detected a fault. Please contact an MG Authorised Repairer as soon as possible.
Front Camera System Fault	It indicates that the front camera has detected a fault. Please contact an MG Authorised Repairer as soon as possible.
Front Camera Calibration Failed	Indicates that the front view camera module (FVCM) calibration has failed. Please contact an MG Authorised Repairer as soon as possible.
RADAR Calibration Failed	Indicates that the radar module calibration has failed. Please contact an MG Authorised Repairer as soon as possible.

Warning Message	Action
Lane Departure Warning System Fault	Indicates that the lane departure warning system (LDW) has detected a fault. Please contact an MG Authorised Repairer as soon as possible.
Emergency Lane Keeping System Fault	Indicates that the emergency lane keeping system (ELK) has detected a fault. Please contact an MG Authorised Repairer as soon as possible.
MG Pilot System Fault	Indicates that the traffic jam assist system has detected a fault. Please contact an MG Authorised Repairer as soon as possible.
Auto Emergency Braking System Fault	Indicates that the auto emergency braking system (AEB) has detected a fault. Please contact an MG Authorised Repairer as soon as possible.

Instruments and Controls

Warning Message	Action
Forward Collision System Fault	Indicates that the forward collision warning system (FCW) has detected a fault. Please contact an MG Authorised Repairer as soon as possible.
Manual Speed Assist Fault	Indicates that the Manual Speed Assist (MSA) function has failed. Please contact an MG Authorised Repairer as soon as possible.
Intelligent Speed Assist Fault	Indicates that the Intelligent Speed Assist (ISA) function has failed. Please contact an MG Authorised Repairer as soon as possible.
ACC System Fault	Indicates that the adaptive cruise control system (ACC) has detected a fault. Please contact an MG Authorised Repairer as soon as possible.

Warning Message	Action
Escape from the vehicle immediately	As soon as conditions permit, safely stop the vehicle and evacuate all occupants immediately, and contact an MG Authorised Repairer immediately.
TBOX Fault	Please contact an MG Authorised Repairer as soon as possible.

Instruments and Controls

Warning Lights and Indicators

Some warning lamps illuminate or flash accompanied by a warning tone.

Main Beam Indicator - Blue



This indicator illuminates when the headlamp high beam is turned on.

Auto Main Beam Indicator - Green



The indicator illuminates when the auto main beam function is enabled.

Dipped Beam Indicator - Green



This indicator illuminates when the headlamp dipped beam is turned on.

Side Lamp Indicator - Green



This indicator illuminates when the side lamps are on.

Rear Fog Lamp Indicator - Yellow



This indicator illuminates when the rear fog lamps are on.

Direction Indicators - Green



The left and right direction indicator lamps are represented by directional arrows that are located at the top of the instrument pack. When the turning signal lamp flashes, the direction indicator lamp on the corresponding side also flashes. If the hazard warning lamps are operated, both direction indicator lamps will flash together. If either direction indicator lamp in the instrument pack flashes very rapidly, it indicates that the turning signal light on the corresponding side has failed.

Note: Failure of a side repeater lamp will have no effect on the flash frequency of direction indicator lamp.

Airbag Warning - Red



If this lamp illuminates, it indicates that the SRS or the seat belt has failed. As soon as conditions permit, safely stop the vehicle and switch the vehicle power system to the OFF position and contact an MG Authorised Repairer immediately. An SRS or seat belt fault may mean the components may not be deployed in the event of an accident.

Seat Belt Unfastened Warning Lamp - Red



If this lamp illuminates or flashes, it indicates that the seat belt for the driver or passenger remains unfastened.

Low-voltage Battery Charging System Malfunction Warning - Red



When the vehicle power system is switched to the ON position this lamp illuminates as part of a self test. When the system is switched to READY the warning light will extinguish. If the warning light illuminates whilst driving, please contact an MG Authorised Repairer at the earliest opportunity.

If the battery power is low, this lamp illuminates and a prompt message appears in the information centre. In this case, the system will restrict or turn off some electrical devices. Please ensure the vehicle power system is in READY mode to charge the battery.

Stability Control/Traction Control System Operation and Fault Warning - Yellow



If this lamp illuminates, it indicates that the stability control system/traction control system has

Instruments and Controls

detected a fault. Please contact an MG Authorised Repairer immediately.

If this lamp flashes while driving, it indicates that the system is operating to assist the driver.

Stability Control/Traction Control System OFF

Warning - Yellow



If the stability control system/traction control system is switched off manually, this warning lamp will illuminate.

Hill Descent Control (HDC) ON/Malfunction

Warning - Green/Yellow



With the HDC button touched, if the lamp illuminates green, it indicates the HDC system has entered the Standby mode. When the lamp flashes green, it indicates that the system is currently under the control of HDC. Touch the HDC button again, the lamp extinguishes, it indicates the HDC function is deactivated.

If a HDC related system suffers a failure, this lamp illuminates yellow. Please contact an MG Authorised Repairer as soon as possible.

For more information, please refer to “Hill Descent Control System (HDC)” in “Starting & Driving” section.

All-Wheel Drive System Indicator Lamp - Green/Yellow *



When the all-wheel drive mode is used, the lamp illuminates green.

If the lamp remains yellow, it indicates the system has detected a fault. Please seek an MG Authorised Repairer immediately.

For more information, please refer to “Driving Mode - AWD” in “Starting & Driving” section.

ABS Warning - Yellow



If this lamp illuminates, it indicates that the ABS has detected a fault. Please contact an MG Authorised Repairer immediately.

If an ABS failure occurs while driving, the ABS function will be disabled while normal braking will still be available. Please contact an MG Authorised immediately.

Booster System / Brake System Warning - Yellow/Red



If the booster system detects a fault, this lamp illuminates yellow. Please slow down, stop the vehicle as soon as safety permits and contact an MG Authorised Repairer immediately.

If the booster system or brake system suffers a serious failure, this lamp illuminates red. Stop the vehicle as soon as safety permits, turn off the START/STOP Switch and contact an MG Authorised Repairer immediately.

Electric Power Steering (EPS) Warning - Yellow/Red



If this lamp illuminates yellow, it indicates the electric power assisted steering system has a general failure and the performance is reduced. Please stop the car as soon as safety permits. If the lamp still illuminates after restarting the vehicle and driving for a short while, please contact an MG Authorised Repairer immediately.

If this lamp illuminates red, it indicates the electric power assisted steering system has a general failure relevant to steering angle sensing. Please contact an MG Authorised Repairer as soon as possible.

If this lamp illuminates red and flashes, it indicates the electric power assisted steering system has a severe failure. Please contact an MG Authorised Repairer immediately.

Tyre Pressure Monitoring System (TPMS)

Warning - Yellow



If this warning lamp illuminates, it indicates that a tyre pressure is low. Please check the tyre pressures.

If this lamp flashes first and then remains illuminated after a period of time, it indicates the system has detected a fault. Please contact an MG Authorised Repairer as soon as possible.

Immobiliser System Warning - Red



If no valid key is detected, this lamp will illuminate red. Please use the correct key, or put the smart key at the alternative starting position. For specific location requirements, refer to "Alternative Starting Procedure" in "Starting & Driving" section.

If the remote key battery is low, this lamp flashes. Please replace the battery as soon as possible.

Electronic Parking Brake (EPB)/ Auto Hold Status Indicator - Red/Green



If this lamp illuminates red, it indicates the EPB system is enabled. If this indicator flashes, it indicates that the vehicle parks on an excessive slope or the EPB system has failed. Please park the vehicle on a safe road. If this indicator continues to flash and the EPB system malfunction warning lamp illuminates, please contact an MG Authorised Repairer as soon as possible.

When the auto hold system is operating to assist the driver, this lamp illuminates green.

Electronic Parking Brake (EPB) System

Malfunction Warning - Yellow



If a fault in the EPB system is detected, this lamp will illuminate. Please contact an MG Authorised Repairer as soon as possible.

READY Indicator - Green



This lamp is used to indicate that the vehicle is ready for driving.

Charging Status Indicator - Yellow



This lamp will illuminate when the vehicle is connected to a charge point and extinguish after charging is completed.

Charging Connection Indicator - Red



This lamp will illuminate when the vehicle is connected to a charge point.

Power System Malfunction Warning - Yellow/Red



If this lamp illuminates yellow, it indicates that the vehicle has detected a fault and power is limited. Please contact an MG Authorised Repairer as soon as possible.

If this lamp illuminates red, it indicates that the vehicle has detected a severe fault. Please stop the vehicle as soon as safety permits, turn off the START/STOP Switch and contact an MG Authorised Repairer immediately.

Motor Overheat Warning - Red



This lamp will illuminate if the motor temperature is too high. Please contact an MG Authorised Repairer as soon as possible.

Motor Malfunction Warning - Red



If a fault or failure is detected in the motor or the power electronic box of the electric drive system,

Instruments and Controls

this lamp will illuminate. Please stop the vehicle as soon as safety permits, turn off the START/STOP Switch and contact an MG Authorised Repairer immediately.

High-voltage Battery Pack Low Battery

Warning - Yellow



This lamp will illuminate when the high voltage battery charge is low. If the voltage continues to drop, this lamp will flash. Where possible please charge the high voltage battery before this lamp enters the flashing stage.

High-voltage Battery Pack Disconnection

Warning - Yellow



When the high-voltage battery pack is connected, this lamp will not illuminate. This lamp will only illuminate when the high voltage battery is disconnected or isolated.

High-voltage Battery Pack Malfunction

Warning - Red



This lamp will illuminate if a fault is detected or the high voltage battery fails. Please contact an MG Authorised Repairer immediately.

This lamp will flash if the high voltage battery temperature is too high. Please stop the car as soon as safety permits, switch the vehicle power system to the OFF position, and leave the vehicle immediately. Contact an MG Authorised Repairer at the earliest opportunity.

Driving Power Limited Warning - Yellow



This lamp will illuminate if the vehicle power has been reduced.

eCall SOS Indicator - Red/Yellow/Green



If the system is ready and an emergency services call (eCall) is in progress, the indicator illuminates green.

If the system is still capable of sending out a vehicle information message to the call centre, but other eCall capabilities are limited due to a fault in the system, the indicator will illuminate yellow. If the eCall system has failed and not operational, the indicator illuminates red. If the yellow or red indicator is illuminated permanently after system self-test, please contact an MG Authorised Repairer immediately.

System Fault Messages Indicator - Yellow



This indicator is used to alert the driver to the fact that there is a warning stored in the vehicle IPK system.

Lane Assist System Indicator - Green/Yellow



This lamp will illuminate yellow when the lane departure warning function is enabled, the lamp will extinguish when the function is disabled. This lamp will illuminate green when the function is activated.



This lamp will illuminate yellow when the emergency lane keeping function is enabled. The lamp will extinguish when the function is disabled. This lamp will illuminate green when the function is activated.

If the Lane Assist System is not able to function normally, the corresponding lamp will flash yellow and then remain on after a period of time. Please contact an MG Authorised Repairer as soon as possible.

For more information, please refer to “Lane Assist System” in “Starting & Driving” section.

Traffic Jam Assist System Indicator - White/Green/Yellow



This lamp will illuminate white when the traffic jam assist function is enabled. The lamp will extinguish when the function is disabled.

This lamp illuminates green when the function is activated.

If the system is not able to function normally the lamp will flash yellow and then remain on after a period of time.

Please contact an MG Authorised Repairer as soon as possible.

For more information, please refer to “Traffic Jam Assist System” in “Starting & Driving” section.

Forward Collision System Indicator - Yellow



This lamp will illuminate yellow when one of the forward collision system functions is disabled.

When all of the forward collision system functions are enabled, if the indicator remains on, it indicates the system is not able to function normally. Please contact an MG Authorised Repairer as soon as possible.

For more information, please refer to “Forward Collision System” in “Starting & Driving” section.

Manual Speed Assist System Indicator - Green/Yellow



This lamp will illuminate yellow when the manual speed assist function is enabled. The lamp will extinguish when the function is disabled.

This lamp illuminates green when the manual speed assist function is activated.

If the manual speed assist system is not able to function normally the lamp will flash yellow and then extinguish. Please try to reinstate this function. If this function cannot be switched on, please contact an MG Authorised Repairer as soon as possible.

For more information, please refer to “Speed Assist System” in “Starting & Driving” section.

Intelligent Speed Assist System Indicator - Green/Yellow



This lamp will illuminate yellow when the intelligent speed assist function is enabled. The lamp will extinguish when the function is disabled.

This lamp illuminates green when the intelligent speed assist function is activated.

If the intelligent speed assist system is not able to function normally, the lamp will flash yellow and then extinguish. Please try to reinstate this function. If this function cannot be switched on, please contact an MG Authorised Repairer as soon as possible.

For more information, please refer to “Speed Assist System” in “Starting & Driving” section.

Manual Speed Assist System Speed Indicator



This lamp will illuminate when the manual speed assist function is enabled. 'NNN' denotes the current setting value of the speed limit.

For more information, please refer to “Speed Assist System” in “Starting & Driving” section.

Speed Limit Sign Indicator - Red



'NNN' denotes the speed value of speed limit sign currently recognized.

When the intelligent speed assist function is activated or speed limit information function (SLIF) warning function is enabled, the lamp will flash if the speed limit value is exceeded. Please slow down.

For more information, please refer to “Speed Assist System” in “Starting & Driving” section.

Adaptive Cruise Control System Indicator - White/Green



If the Adaptive Cruise function is enabled, the Adaptive Cruise Control System will enter the standby state. The lamp illuminates white.

Instruments and Controls

When the Adaptive Cruise Control System operates, the lamp will illuminate green. This indicates that the Adaptive Cruise Control System is activated.

Refer to “Adaptive Cruise Control System” in “Starting & Driving” chapter for more information.

Adaptive Cruise Control System Malfunction

Indicator Lamp - Yellow



This lamp will illuminate if a Adaptive Cruise Control System failure is detected. Please contact an MG Authorised Repairer as soon as possible.

Refer to “Adaptive Cruise Control System” in “Starting & Driving” chapter for more information.

Rear Drive Assist System Indicator - Yellow



If the rear drive assist system is turned off, this lamp illuminates with prompt messages.

If any of the rear driver assist sensors are obscured or if the system detects a fault, this lamp will illuminate,

accompanied by prompt messages. Please contact an MG Authorised Repairer as soon as possible.

Refer to “Rear Driving Assistance System” in “Starting & Driving” chapter for more information.

Driver Attention Warning System Warning Lamp - Yellow



When the driver attention warning system calculates that the driver is becoming fatigued and it needs to provide an alarm, this lamp will illuminate accompanied by a prompt message.

If the system detects a fault, this lamp will illuminate accompanied by a prompt message.

Refer to “Driver Attention Warning System” in “Starting & Driving” chapter for more information.

Note: There are some circumstances where a warning light may illuminate or a warning message is displayed as an indication of an issue with the associated system, this does not necessarily indicate a fault. If in doubt, please seek advice from an MG Authorised Repairer.

Lights and Switches

Master Light Switch

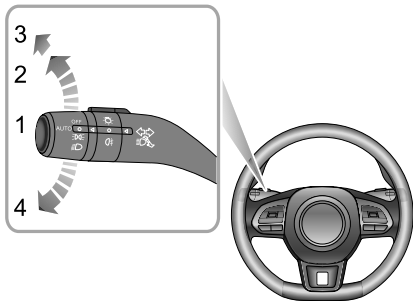

- 1 AUTO Lamp
- 2 Side Lamp and Switch Illumination
- 3 Dipped Headlamps
- 4 Lamps Off

AUTO Lamp

When the START/STOP Switch is in the ACC position, the auto lighting system defaults to the ON position (1). The AUTO lighting system will automatically switch the side lamps and switch illumination on and off according to the intensity of current ambient light.

With the START/STOP Switch in the ON/READY position, the AUTO lighting system will automatically switch the side lamps, switch illumination and dipped beam headlamps on and off according to the intensity of current ambient light.

Side Lamp and Switch Illumination

When the START/STOP Switch is in the OFF or ACC position, rotating the master light switch to position 2 will switch on the side lamps and switch illumination. When the START/STOP Switch is in the ON/READY position, rotating the master light switch to position 2 will switch on the daytime running lamps, rear side lamps and switch illumination. With the START/STOP Switch in the OFF position, if the side lamps stay on when the driver's door is opened, an audible alarm will sound.

Instruments and Controls

Headlamps

When the START/STOP Switch is in the ON/READY position, rotate the master light switch to position 3 to switch on the dipped beam headlamps and side lamps.

Lamps Off

Rotate the master light switch to position 4 to switch off the lamps. Releasing the switch will allow it to return to the AUTO switch position.

Welcome Light

When the car is unlocked, the system will automatically illuminate the dipped beams, side lamps and puddle lamps according to the intensity of the current ambient light.

Follow Me Home

After the START/STOP Switch is turned off, pull the lighting switch/indicator stalk towards the steering wheel. This will enable the Follow Me Home function. Dipped beam headlamps and side lamps will illuminate depending upon the vehicle configuration.

Daytime Running Lamps

The daytime running lamps illuminate automatically when the START/STOP Switch is in the ON/READY position. When the dipped headlamps are switched on, the daytime running lamps extinguish automatically.

Headlamp Leveling Manual Adjustment

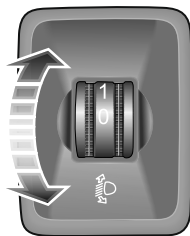

The headlamp leveling can be adjusted as per the following table according to the vehicle load.

Instruments and Controls

Location	Load
0	Driver, or driver & front passenger
1	All the seats occupied with no load in the bootspace
2	All the seats occupied plus an evenly distributed load in the bootspace
3	Driver only, plus an evenly distributed load in the bootspace

Direction Indicator/Main Beam Switch



Take care not to dazzle oncoming vehicles when driving using main beam headlamps.

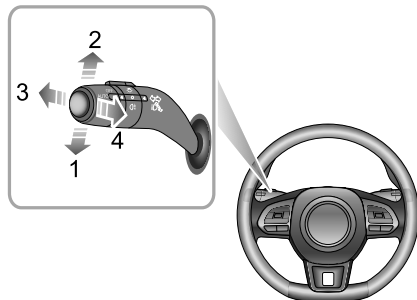

Direction Indicators

Move the light stalk switch down to indicate a LEFT turn (1). Move the light stalk switch up to indicate a RIGHT turn (2). The corresponding GREEN direction indicator in

Instruments and Controls

the instrument pack will flash when the turn signal lamps are working.

Rotating the steering wheel will cancel the indicator operation (small movements of the steering wheel may not initiate the self cancelling). To indicate a lane change, move the lever briefly and release, the indicators will flash three times and then cancel.

Main/Dipped Beam Headlamps Switching

With the START/STOP Switch in the ON/READY position and the headlamps on, push the light stalk switch towards the instrument panel (3) to turn on main beams. At this time, the main beam indicator in the instrument pack will illuminate and the message centre will prompt "Main Beam On". Push the light stalk switch (3) once again to switch to dipped beams.

Main Beam Flash

To briefly flash the main beam on and off, pull the lever towards the steering wheel (4) and then release.

Smart Main Beam System



The smart main beam system serves only as an auxiliary function. The driver must check the status of the front lamps, and turn on the front lamps when necessary.

For example: The main beam may not be turned off automatically in the following cases, thus manual switching between the main beam and dipped beam is required:

- The windscreen is dirty, broken or obstructed by other objects blocking the view of the sensor.*
- The lamps of other vehicles are missing, damaged, blocked or cannot be detected due to weather and other reasons.*
- When pedestrians, non-motor vehicles and other objects with no obvious light or reflected light are encountered.*
- When the headlamps and tail lamps of other vehicles cannot be detected due to the sensor view being impaired due*

undulating road conditions such as bends, dips or hills.

- When the car is driving on a winding road or mountainous road.*

The Smart Main Beam System is designed to detect the light intensity information of the vehicle in front using the vehicle forward camera and switch the main beam on or off when certain conditions are met. When the smart main beam system is enabled, the smart main beam indicator in the instrument pack illuminates. For some models, the smart beam function can be switched on/off via the infotainment system.

In the case of automatic control, the system will automatically turn on the main beam when the surrounding environment is dark and there is no light detected from any vehicles ahead, or oncoming vehicles; when the surrounding environment is bright enough or the system detects the headlamps or tail lamps of the vehicle ahead or oncoming vehicles, the system will automatically turn off the main beam.

To enable the smart main beam system, the following conditions must be met:

Instruments and Controls

- 1 The master lighting switch must be in the Auto position and the dipped beam lamps switched on via automatic control.
- 2 The vehicle is running and the speed is above 40km/h.

If the following conditions are met, the vehicle will automatically exit the smart main beam system. If the system exits, quickly push the direction indicator/main beam switch (main beam 'ON') towards the instrument pack twice to enter the smart main beam system again. You can only exit three times in one ignition cycle. If you exit more than three times, you will not be able to enable this function again in the current ignition cycle.

- When the smart main beam system is enabled and the dipped beam lights are automatically turned on and the lighting system is manually switched to the main beam lights.
- When the smart main beam system is enabled and the main beam lights are automatically turned on and the lighting system is manually switched to the dipped beam lights.

- When the smart main beam system is enabled, the main beams are automatically turned on and the main beam flash switch is operated.

IMPORTANT

The smart main beam function uses data from the front view camera, always keep the windscreen clean and free from residue in this area to maintain optimum performance of this system. Any damage in this area, such as stonechips must be repaired at the earliest convenience.

Rear Fog Lamps



Fog lights should only be used when visibility is below 100m - other road users could be dazzled in clear conditions.

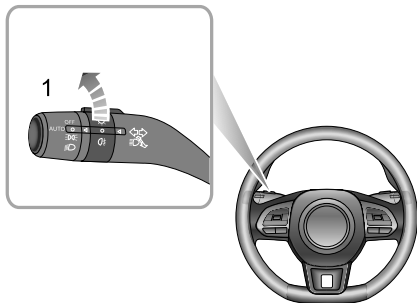

Hazard Warning Lamps

Press the hazard warning lamp button  to turn on the hazard warning lamps. At this time, all turn signal lamps and direction indicators will flash together. Press the button again to turn off the hazard warning lamps. All turn signal lamps and direction indicators will stop flashing.

1

With the START/STOP Switch in the ON/READY position and the headlamps on, rotate the fog lamp switch to position I to turn on the rear fog lamps. The rear fog lamp indicator illuminates in the instrument pack when the rear fog lamps are on.

Note: *The rear fog lamps will turn off automatically when the master light switch is switched off.*

Wipers and Washers

Front Windscreen Wiper Controls

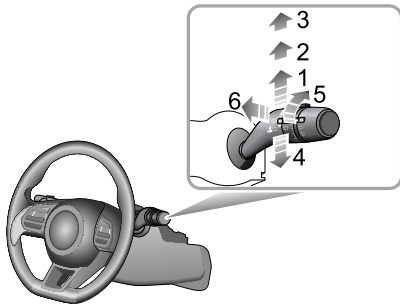

The wipers and washers will only operate when the START/STOP Switch is in the ON/READY position. Operate the lever to select different wiping modes:

- Intermittent wipe (1)
- Slow speed wipe (2)
- Fast speed wipe (3)

- Single wipe (4)
- Rain sensor sensitivity adjustment (5)
- Programmed wipe (6)

Intermittent Wipe

By pushing the lever up to the Intermittent wipe position (1), the wipers will operate automatically.

Vehicles are equipped with a rain sensor fitted to the interior rearview mirror base to detect varying amounts of water on the outside of the windscreen. With automatic wipe, the vehicle will adjust the wiping speed according to the signals provided by the rain sensor. Rotate the switch (5) to adjust the sensitivity of the rain sensor. As the sensitivity increases, the wiping interval decreases.

Note: Immediately operating the wiper one time can be achieved by increasing the sensitivity of the rain sensor. If the rain sensor detects continuous rainwater, the wipers will keep working. When it is not raining, it is recommended to switch off automatic wipe.

Instruments and Controls

Slow Speed Wipe

By pushing the lever up to the slow speed wiping position (2), the wipers will operate slowly.

Fast Speed Wipe

By pushing the lever up to the fast speed wiping position (3), the wipers will operate at fast speed.

Single Wipe

Pressing the lever down to the single wiping position (4) and releasing will operate a single wipe. If the lever is held down (4), the wipers will operate continuously until the lever is released.

Note: *When the car is stationary, if the bonnet is opened, the front wiper/washer operation will be disabled.*

IMPORTANT

- Avoid operating the wipers on a dry windscreen.
- In freezing or extremely hot conditions, make sure that the wiper blades are not frozen or adhered to the windscreen.
- In winter, remove snow or ice from around the wiper arms and blades, including the wiped area of the screen.

Programmed Wipe

Pulling the lever toward the steering wheel (6) will operate the front windscreen washers. After a short delay, the wipers will commence operating in conjunction with the washers.

Note: *The wipers continue operating for a further three wipes after the lever is released. After several seconds, there will be a further wipe to remove any fluid draining down the screen.*

Instruments and Controls

IMPORTANT

If the washers fail to deliver the screen wash solution (dirt or ice may have blocked the jets), release the lever immediately. This will prevent the wipers from operating, and the consequent risk of visibility being impaired by dirt smearing across the unwashed windscreen.

Rear Windscreen Wiper Controls

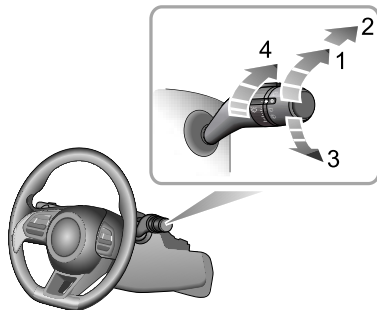

The rear wipers and washers will only operate when the START/STOP Switch is in the "ON/READY" position. Rotate the rear window wiper switch to your desired selection:

- Intermittent wipe (1)
- Wash and wipe (2)
- Wash and wipe (3)
- Wipe interval adjustment (4)

Intermittent position

If the rear wiper switch is rotated to intermittent wipe (1), the rear wiper will operate. It will complete 3 continuous wipes before changing to intermittent mode. The time period between the wipes can be increased/decreased via the switch (4).

Wash and wipe

Rotate the rear window wiper switch to wash and wipe (2) position and hold, the rear window wiper and washer will operate, the rear window wiper wipes quickly. Release the switch allowing it to return to intermittent wipe (1), the rear window washer will stop operating.

Rotate the rear window wiper switch to wash and wipe (3) and hold, the rear window wiper and washer will operate. Release the switch allowing it to return to OFF position, the rear window washer will stop operating, and the rear window wiper will wipe 3 times. After several seconds, the wiper will wipe once more to remove the washer fluid on the windscreen.

Note: *When the tailgate is opened, rear wiper operations will be disabled.*

Note: *When the windscreen wipers are switched on, if Reverse gear is selected , the rear window wiper will operate.*

Instruments and Controls

Steering System

Adjustment of Steering Column



DO NOT attempt to adjust the angle or height of the steering column while the car is in motion. This is extremely dangerous.

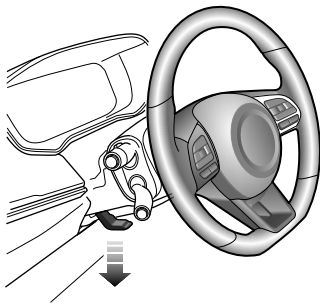

To adjust the angle or height of the steering column to suit your driving posture:

- 1 Fully release the locking lever.
- 2 Hold the steering wheel in both hands and tilt the steering column up or down to move the wheel into the most comfortable position.
- 3 Push or pull the steering wheel towards or away from the body.
- 4 Once a comfortable driving position has been selected, pull the locking lever fully up to lock the steering column into its new position.

Electric Power Steering



If the electric power steering fails or cannot operate the steering will appear very heavy, this will affect driving safety.

The electric power steering system only works when the vehicle is in READY mode. The system operates via a motor with assistance levels automatically adjusted based on vehicle speed, steering wheel torque and steering wheel angle.

IMPORTANT

Holding the steering wheel on full lock for long periods will result in a reduction in power assistance causing a heavier feel to the steering for a short period of time.

Instruments and Controls

Horn



Press the horn button area on the steering wheel (as indicated by the arrow) to operate the horn.

Note: *The vehicle horn button areas and the driver's airbag are located in close proximity on the steering wheel. The illustration shows the position of the horn (indicated by arrow). Please ensure that you press*

in this area to avoid any potential conflict with the operation of the airbag.

IMPORTANT

To avoid possible SRS issues, please do not press with excessive force or hit the airbag cover when operating the horn.

Mirrors

The vehicle is fitted with rear view mirrors. These consist of a door mirror fitted to each door and a centrally mounted interior mirror. Rear view mirrors reflect situations directly behind or on both sides of the vehicle thus expanding the driver's field of vision.

The rearview mirrors are safety-critical parts. Proper use and reasonable mirror angle adjustment can improve the driver's driving safety and comfort.

Exterior Rearview Mirrors

Note: *Objects viewed in door mirrors may appear further away than they actually are.*

The exterior rearview mirrors feature an electric folding function, this helps avoid damage and allows folding when manoeuvring through narrow passages.

In addition to the electronic folding function, each mirror glass features heating elements and electronic angle adjustment with a memory function.

Mirror Glass Heating

The door mirrors have integral heating elements which disperse ice or mist from the glass.

The heating elements operate while the Heated Rear Window  is switched on.

Note: *The heating elements of the rear window and door mirror will only work when the START/STOP Switch is in READY mode.*

Electric Folding

Pressing the switch (arrowed) on the combination switch in the driver side switch panel will electrically fold the exterior door mirrors. Pressing this switch again will restore the mirrors to their original position.

Instruments and Controls

Electric Adjustment of Mirror Glass

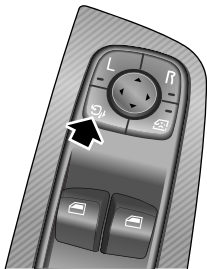

While unlocking/locking the vehicle, the exterior door mirrors will be deployed/folded automatically.

Note: *Electrical folding door mirrors that have been moved from their positions by manual or accidental means must be reset by operating the switch to completely fold and deploy once.*

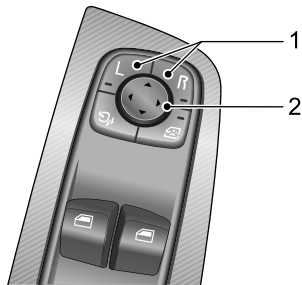

- Press the left (L) or right (R) switch (1) to select the left or right exterior door mirror. The indicator lamps within the switches (1) will illuminate when selected.
- Press one of the 4 arrows of the circular switch (2) to adjust the angle of the exterior door mirror.
- Press the L or R switch (1) again. The corresponding indicator lamp will extinguish, and the mirror adjustment operation will be stopped. This is to

avoid accidental adjustment of the mirror angle once adjustments have been made.

Note: *Mirrors that are equipped with the mirror memory function can be set along with the driver seat position memory. This is reflected in driver personalisation and enhances convenience. (See "Driver's Seat Personalisation Function" in "Seats & Restraints").*

Mirror Angle Memory Function during Reversing

To provide the driver with a better view of the rear wheels and the road surface behind the vehicle during reversing, the mirror glass can be automatically tilted down during reversing, and the tilt angle can be memorized. This function can be enabled or disabled through the entertainment system display.

The steps for setting the automatic tilt angle of the mirror during reversing are as follows:

- Set to READYmode and select R;
- Adjust the rearview mirror glasses on both sides to a preferred angle (the mirror glass tilts down);

- Remove from R and select P/D/N.

IMPORTANT

- Exterior door mirrors are operated by electrical motors. Operating them directly by hand may damage the internal components.
- Washing or flushing exterior door mirrors with high pressure water jets or car washes may result in electrical motor failure.

Puddle Lamp

Puddle lamps are integrated within the lower half of the door mirrors.

Instruments and Controls

Interior Rearview Mirror

Before driving, adjust the body of the interior rearview mirror to achieve the best possible view. The anti-dazzle function of the interior rearview mirror helps to reduce glare from the headlamps of vehicle approaching from the rear at night.

Automatic Anti-dazzle Interior Rearview Mirror *

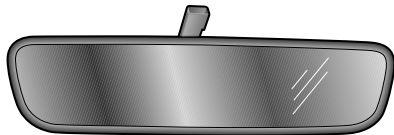

When the START/STOP Switch is in the ON/READY position, the automatic anti-dazzle function is switched on automatically. When a following vehicle's headlamps could

dazzle the driver, the light sensor activates the anti-dazzle function.

The automatic anti-dazzle function can be inhibited if:

- The light from the vehicle behind is not seen by the light sensor on the mirror.
- Reverse gear is selected.

Note: *Attaching film or objects on the rear window may influence the automatic anti-dazzle function.*

Manual Anti-dazzle Interior Rearview Mirror*



Move the lever at the base of the interior rearview mirror to change its angle, so as to achieve the anti-dazzle function. Normal visibility is restored by pulling the lever back again.

Note: *In some circumstances, the view reflected in a 'dipped' manual mirror can confuse the driver as to the precise location of rear approaching vehicles.*

Instruments and Controls

Sunvisor



The vanity mirror on the driver side should only be used when the car is stationary.

switched on when the cover is opened, and it is switched off when the cover is closed.

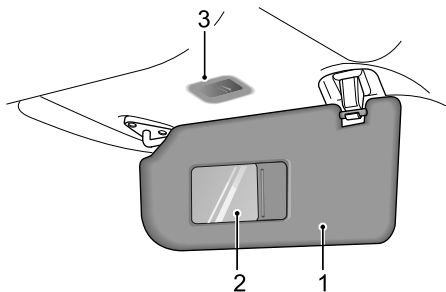

The Sunvisor (1), vanity mirror (2) and vanity mirror light (3) are arranged on the roof ahead of both the driver and the front passenger.

Pull the sunvisor downward to use the vanity mirror. If the roof has vanity mirror lights, a vanity mirror light is

Windows



Please operate the windows correctly to avoid danger. The driver should instruct the occupants on the use of windows and safety precautions.



Ensure children are kept clear when raising or lowering a window. Even though some windows feature an anti trap function, it is possible that children or objects may become trapped during window operation. Improper use or activation of the electric windows by children could cause serious harm or even death. It is the responsibility of the driver and adult passengers to ensure that when carrying children the necessary steps are taken to isolate the window operation. This should include the removal of the key when children are left alone in the vehicle.



***DO NOT** operate the power window controls continuously several times in a short time frame, otherwise the power window controls may be disabled to protect the motor. If this occurs, please wait a few seconds until the motor cools down. In the case of the driver's window with "One Touch and Anti-Trap", please wait 30 seconds prior to operation. In some cases it may take 30 minutes to completely cool down, during which time the negative battery lead should not be disconnected.*

Instruments and Controls

Power Operated Window Switch

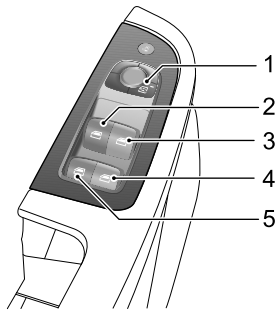

- 1 Rear Window Isolation Switch
- 2 Front Left Window Switch
- 3 Front Right Window Switch
- 4 Rear Right Window Switch
- 5 Rear Left Window Switch

Window Operation

The electric windows can be operated with the vehicle power system in the ACC, ON and READY positions. (For safety: doors should be closed).

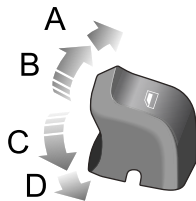

Each window switch is designed as a 2 stage switch. Press the window control switch (2 ~ 5) to the first position (C) to lower the window; and lift the switch to the first position (B) to raise. The window will stop moving as soon as the switch is released. Release the switch and the window stops.

“One-Touch” Down

Briefly press the window control switch to the second position (D). The window automatically descends to fully

open. Window movement can be stopped at the desired position at any time by briefly operating the switch again.

“One Touch” Up with “Anti-Trap”

Briefly lift the window control switch to the second position (A). The window automatically raise to fully closed. Window movement can be stopped at the desired position at any time by briefly operating the switch again.

The “Anti-Trap” function is a safety feature which prevents the window from fully closing if an obstruction is sensed - if this happens the window will open slightly to allow the obstruction to be removed.

Note: The front and rear passenger windows can also be operated by individual window switches, mounted on each door. The rear window switches will not operate if the rear window isolation switch has been activated.

Rear Window Isolation Switch

Press the switch (1) to isolate the rear window controls (an indicator lamp in the switch illuminates). Press again to restore control.

Note: It is recommended that you ISOLATE the rear window switches when carrying a child.

“Lazy Lock” Function

The “Lazy Lock” function can open or close all the windows by using the remote key from outside the vehicle as long as it is within detection range.

After the vehicle is powered off and the doors are closed, press and hold the remote key unlock button until the windows start to open. Release the unlock button. All windows will open fully. With the windows open, press and hold the remote key lock button until the windows start to close. Release the lock button. The windows will completely close.

Note: If there is a power interruption during the raising or lowering of the window, One Touch and Anti-Trap mode may be not operational. In this case, fully open the window, then raise the window to the fully closed position by lifting the switch briefly and consecutively. When the window is fully closed, hold the switch in the close position for a further 5 seconds . Then fully

Instruments and Controls

open the window again, press and hold the switch for another 5 seconds.

Sunroof

Instructions



DO NOT allow passengers to lean out of an open sunroof whilst the vehicle is in motion. Injuries may occur from objects such as tree branches.



Safety of the vehicle occupants must be observed at all times. DO NOT allow limbs to be placed in the moving path of the sunroof at any time. Injuries may occur.

- Avoid fully opening the sunroof during rain showers.
- It is advised not to open the sunroof at high speeds.
- Where possible, please clean any residual water or raindrops off the sunroof prior to opening. Failure to do so may result in water entering the car.
- DO NOT use abrasive materials to clean the sunroof glass. Use alcohol based solvent.
- DO NOT hold the operating switch in the open/close position for any length of time after operation

is complete. This could damage the electrical components.

- Clean the sunroof regularly to maintain operation and performance. Visit an MG Authorised Repairer for service as required.

Instruments and Controls

Sunroof Operation

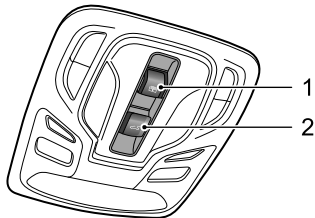

When the START/STOP Switch is set to ACC or ON/READY, you can operate the sunroof.

The sunroof assembly consists of two glass panels and one sunroof sunshade. The front glass panel can be opened by sliding or tilting. The rear glass panel is fixed and cannot be opened. The sunshade can slide open. Switch 1 is used to operate the sunroof sunshade, and switch 2 is used to operate the sunroof glass. The method by which the sunroof will open is identified by the icons on the switches.

Sunroof Glass Operation

Open the Sunroof Glass by Tilting

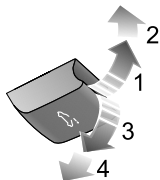

Push the sunroof glass switch upward to the 1st position (1) and hold. The sunroof will tilt open. You can stop the movement of the sunroof at any time by releasing the switch. Push the glass switch with slightly harder force to move the switch to its 2nd position (2) and then release, the sunroof will automatically open completely.

Close the Sunroof Glass by Tilting

Pull the sunroof glass switch downward to the 1st position (3) and hold. The sunroof will close. You can stop the movement of the sunroof at any time by releasing the switch. Pull the glass switch with slightly harder force to

move the switch to its 2nd position (4) and then release, the sunroof will automatically close completely.

Open the Sunroof Glass by Sliding

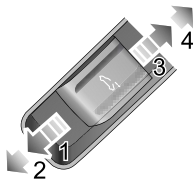

Push the sunroof glass switch backward to the 1st position (3) and hold. The sunroof will slide open. You can stop the movement of the sunroof at any time by releasing the switch. Push the glass switch backward with slightly harder force to move the switch to its 2nd position (4) and then release. The sunroof will automatically open fully. You can stop the movement of the sunroof at any time by pushing the switch backward again.

Close the Sunroof Glass by Sliding

Push the sunroof glass switch forward to the 1st position (1) and hold. The sunroof will close. You can stop the movement of the sunroof at any time by releasing the switch. Push the glass switch forward with slightly harder force to move the switch to its 2nd position (2) and then release. The sunroof will automatically fully close. You can stop the movement of the sunroof at any time by pushing the switch forward again.

Sunroof Sunshade Operation

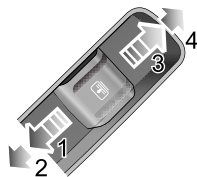

Open the Sunshade

Push the sunroof sunshade switch backward to the 1st position (3) and hold. The sunshade will slide open. You can stop the movement of the sunshade at any time by

Instruments and Controls

releasing the switch. Push the sunshade switch backward with slightly harder force to move the switch to its 2nd position (4) and then release. The sunshade will automatically open fully. You can stop the movement of the sunshade at any time by pushing the switch backward again.

Close the Sunshade

Push the sunroof sunshade switch forward to the 1st position (1) and hold. The sunshade will close. You can stop the movement of the sunshade at any time by releasing the switch. Push the sunshade switch forward with slightly harder force to move the switch to its 2nd position (2) and then release. The sunshade will automatically fully close. You can stop the movement of the sunshade at any time by pushing the switch forward again.

Note: If the vehicle is to be parked in direct sunlight for a length of time, it is recommended that the sunshade be closed to protect the interior trim components from damage, and to help regulate the in car temperatures.

Anti-pinch Function

The sunroof and sunshade feature an “Anti-Pinch” function. This is a safety feature which prevents the sunroof or sunshade from fully closing whilst in the automatic mode if an obstruction is sensed - if this happens, the sunroof/sunshade will open slightly to allow the obstruction to be removed.

Forcibly Closing the Sunroof (over-riding the anti pinch)

To forcibly close the sunroof glass after an anti-pinch intervention, gently slide the glass switch forward to the 1st position within 5 seconds and hold in position until the sunroof glass is fully closed.

Note: The anti pinch function is suspended during this operation.

Forcibly Closing the Sunshade

To forcibly close the sunshade that has reopened due to activation of the anti-pinch function: gently slide the sunshade switch forward to the 1st position within 5 seconds and hold it until the sunshade closes fully.

Note: *The anti pinch function is suspended during this operation.*

Linkage between Sunshade and Sunroof Glass

To prevent the sunshade from being exposed, the sunshade will move together with the sunroof glass as one unit when the sunroof is opened. To close the sunshade, please close the sunroof glass first.

Sunroof Initialisation

In the event of a power failure or battery disconnection when the sunroof glass or sunshade is in motion, the sunroof/sunshade will require initialisation when the power is restored.

Sunroof glass initialisation operation : gently slide the switch forward to the 2nd position and hold in position for about 10 seconds. The sunroof will open a preset amount and stop. It will then close automatically - the sunroof glass is then initialised. During the whole process, the switch must remain in the 2nd position.

Sunshade initialisation operation: slide the close switch forward to the 2nd position and hold in position for about

10 seconds. The sunshade will open a preset amount and stop. It will then close automatically - the sunshade is then initialised. During the whole process, the switch must remain in the 2nd position.

Thermal Protection

To prevent the sunroof glass motor and the sunshade motor from being overheated and damaged, the motors are designed with a thermal protection function. Any opening or closing operation whilst in the thermal protection state will not move the sunroof.

"Lazy Lock" Function

"Lazy Lock" function can open or close the sunroof from outside the vehicle.

Press and hold the remote key unlock button for several seconds until the sunroof glass and sunshade start to open, then release the button, the sunroof will continue to open until it is fully opened; with the sunroof open, press and hold the remote key lock button for several seconds until the sunroof glass and sunshade start to close, then release the button, the sunroof will continue to close until it is fully closed.

Instruments and Controls

Interior Light

Front Interior Lamp

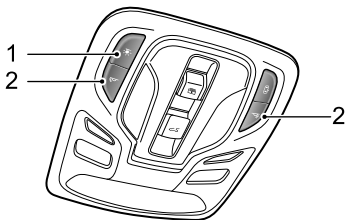

Press switch 1 to turn on the front interior lamps. Press again to turn off.

Press either of the buttons 2 to turn on a corresponding front interior lamp. Press again to turn off.

Rear Interior Lamp

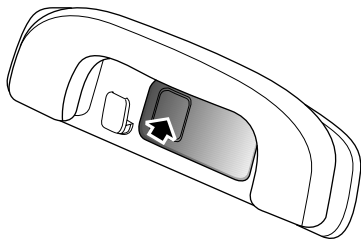

The rear courtesy lights are located on the left and right sides of interior roof panel. Press the lamp lens as indicated in the diagram to switch on the rear courtesy lights. Press it again to switch off the lights.

Automatic Operation

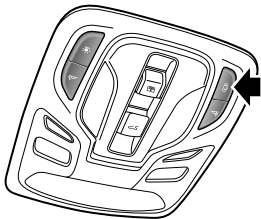

Press the button indicated in the picture to turn on or turn off the automatic function.

When the automatic control function is enabled, the front and rear interior lamps illuminate automatically if any of the following actions are carried out:

- The car is unlocked.
- Any door is opened.
- When the vehicle light sensor detects that the ambient light level is low or if the side lights have been illuminated within the previous 30 seconds, the interior light will operate when the START/STOP Switch is set to OFF.

Note: If a door is left open beyond a preset time, the interior lamps will be switched off automatically to avoid battery drain.

Ambient Lighting*

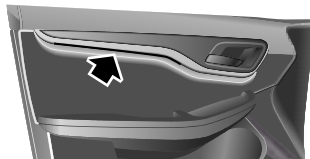

Ambient lighting is fitted on certain models to create a comfortable atmosphere inside the car. The control of the ambient lamps can be set in the infotainment system.

Power Socket

Front Console Power Socket



Please ensure the socket lid is inserted when the power socket is not in use. This will ensure no debris or foreign objects enter the socket, preventing its use or causing short circuits.

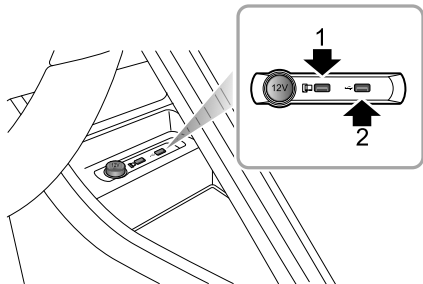

The 12V front console power socket is located in the front of console. When the START/STOP Switch is in the ACC or ON/READY positions, it can be used as a power supply.

There are 2 USB ports (1 & 2) equipped to the right of the 12V front console power socket. The USB ports can provide a 5V voltage when serving as a power outlet, or realize data transmission. USB port 1 can also provide the 'Vehicle-Mobile Phone Interconnection' function.

Note: The voltage of the front console power socket is 12 volt, and the power rating is 120 watt. Do Not use electrical equipment with the power exceeding the rating.

Note: Extended use of the accessory power socket and USB socket when the vehicle power system is switched off will cause premature discharging of the vehicle battery.

Note: The USB ports may not support some fast charging devices.

Note: No cigarette lighter is available on the vehicle. If required, please consult an MG Authorised Repairer.

Rear Console USB Charging Ports

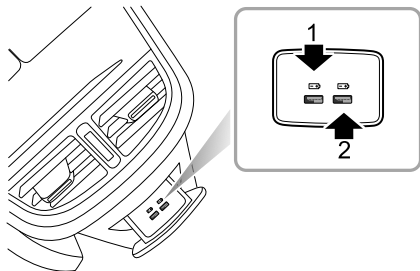

Note: Use of the rear console USB port when the vehicle is not in READY mode will consume battery power, extended use will cause premature discharging of the vehicle battery, and the vehicle may be prevented from being switched into READY mode.

Note: The USB ports may not support some fast charging devices.

There are 2 USB ports (1 & 2) at the rear of the centre console (open the small storage box). When the START/STOP Switch is in the ACC or ON/READY positions, the USB ports can provide 5V voltage serving as power outlets.

Close the small storage box after using the USB ports.

Instruments and Controls

Wireless Charging System for Mobile Phones *

The wireless charging function for a mobile phone is realized without the necessity for a connection cable. It is achieved using electromagnetic induction.

Note: *The wireless charging function does not apply to all mobile phones, only brands/models with wireless charging function.*

Wireless Charging of Mobile Phones

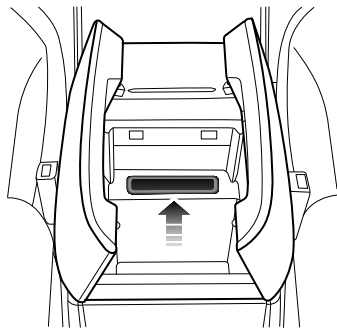

The wireless charging area is located in the front storage box. The charging function is enabled when the START/STOP Switch is placed in the ACC/ON/READY positions. Open the storage box cover and place the phone vertically in the card slot. The charging coil of the mobile phone should be facing front. This can be used for wireless charging.

Instruments and Controls

Note: *Only one mobile phone can be charged at a time.*

Note: *On bumpy roads, the wireless charging function of the mobile phone may intermittently stop and resume. If the mobile phone deviates from the charging area and stops charging, it will need to be placed back in the rechargeable area.*

Note: *The size of each brand of mobile phone is different, and the position of the charging coil on the mobile phone is different. Please adjust the position of the mobile phone properly. In addition, the case of some mobile phones has an impact on wireless charging. It may be necessary to adjust or remove the case to achieve wireless charging.*

If the mobile phone cannot be charged correctly, please make sure that there is no foreign matter in the wireless charging area or wait for the wireless charging area to cool down before further attempts. If it still fails, seek an MG Authorised Repairer.

IMPORTANT

When the wireless charging system of the mobile phone is being used, make sure that the smart key is 20cm or more away from the wireless charging area.

Do not place coins, IC cards, metal keys, or other items with a large amount of metal composition in the wireless charging area with your phone. This may result in the failure of wireless charging function and create a safety hazard.

Instruments and Controls

Storage Devices

Instructions

- Please close all storage devices when the car is in motion. Leaving these storage devices open may cause personal injuries in cases of a sudden start-off, emergency braking and a car accident.
- Do not place flammable materials such as liquid or lighters in any storage devices. The heat in hot conditions may ignite flammable materials and lead to a fire.

Glove Box

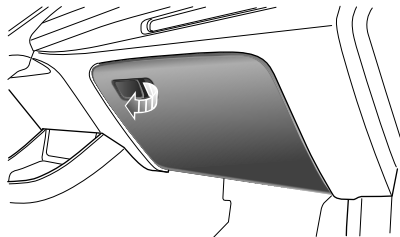

To open the glove box, pull the handle on the glove box cover (as indicated by the arrow). The glove box light will automatically illuminate.

Push the lid forward to close the glove box. Make sure the glove box is fully closed when the car is being driven.

Instruments and Controls

Centre Console Front Storage Box

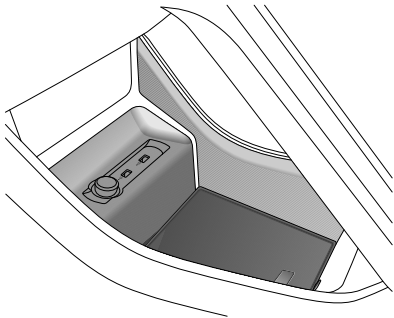

The front storage box is below the display screen.

Centre Console Armrest Box

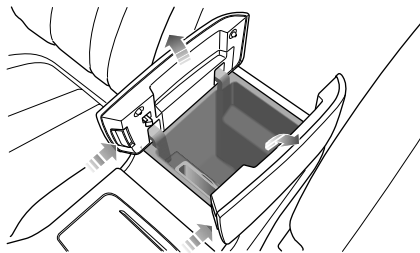

Press the buttons to the front of each cover and lift to open the cover (as indicated by the arrow), Push the cover down to close it.

Some models feature a mobile phone box with wireless charging in the armrest box.

Instruments and Controls

Cup Holder



DO NOT place hot drinks in the cup holder whilst driving. Spillage may result in personal injury or damage.

Centre Console Cup Holder

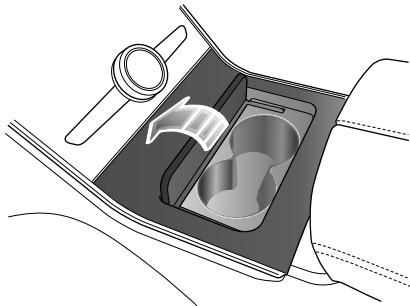

The centre console cup holder is situated at the front end of the centre console armrest assembly. Press the cover of the cup holder to open.

Rear Armrest and Rear Cup Holder

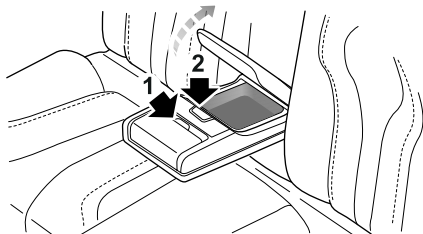

Fold forward to open the rear armrest. Press button 1 to open the cup holder. Press button 2 to open the storage box in the rear of the armrest.

Roof Luggage Rack



Roof loads MUST NOT exceed the maximum authorised load. This may lead to injury or vehicle damage.



Loose or improperly fixed loads may fall from the roof luggage rack and lead to an accident or cause injury.



When heavy or large items are carried on the roof luggage rack it may lead to changes in steering, handling and braking characteristics. Please avoid sharp maneuvers, heavy braking and excessive acceleration.

Pay attention to the following when using the roof luggage rack:

- Fix loads towards the front of the roof as far as possible, and distribute the roof load evenly.
- DO NOT use automatic car washes with loads on the roof luggage rack.

- The overall height of the car is different when loads are fitted to the roof luggage rack. Please ensure there is adequate clearance when entering tunnels and garages.
- Ensure the loads carried by the roof luggage rack do not impede operation of the sunroof, roof antenna or tailgate opening.
- When installing or removing a piece of loading equipment, follow the instructions provided by the manufacturer of the loading equipment.

Maximum Authorised Load for the Roof

The maximum authorised load for the roof is 50 kg, the roof load includes the weight of any roof loads and that of any loading equipment installed.

Ensure you are aware of the weight of loads, and weigh them when necessary. Never exceed the maximum authorised load for the roof.

Periodical Check

Always check the condition and security of the bolt connectors and fasteners before using the roof luggage rack. Periodically check the condition and security of bolt connectors and fasteners.

Air Conditioning and Audio Systems

80 Ventilation

82 Automatic Temperature Control

Air Conditioning and Audio Systems

Ventilation

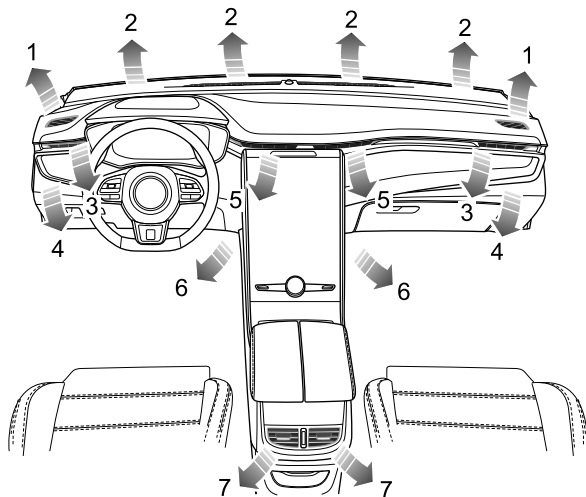

- 1 Front Side Window Vents
- 2 Windscreen/Defrost Vents
- 3 Side Vent - Upper
- 4 Side Vent - Lower
- 5 Centre Vents
- 6 Front Footwell Vents
- 7 Centre Console Vents

There are also 2 rear footwell vents respectively on the floor under the front seats (not shown in the figure).

Air Conditioning and Audio Systems

The air conditioning system is used to adjust the temperature, speed, humidity and cleanliness of the air in the car. Fresh air is drawn in through the air intake grille at the base of the front windscreen and A/C filter.

Always keep the air intake grille clear of obstructions such as leaves, snow or ice.

A/C Filter

The A/C filter is used to filter air. To remain fully effective, the filter should be replaced at the recommended service interval.

Centre Console Vents

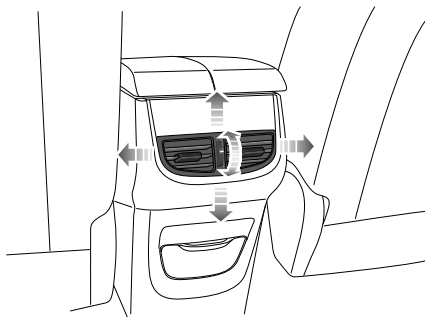

Rotate the thumb-wheel up or down to open or close the vents.

Slide the button in the centre of the louvres up and down, left and right to adjust the air direction.

Note: Vent selection can be set in the entertainment screen.

Air Conditioning and Audio Systems

Automatic Temperature Control

Control Interface

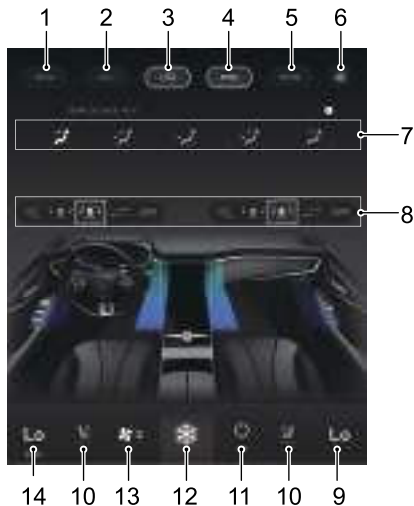

- 1 Auto Mode
- 2 Cooling On/Off
- 3 Air Recirculation Mode
- 4 Temperature Zone Control
- 5 Economy Mode
- 6 A/C Setting
- 7 Air Distribution Mode
- 8 Intelligent Electric Air Vent Control
- 9 Right Temperature Control
- 10 Seat Ventilation and Heating *
- 11 System On/Off
- 12 A/C Control Interface Shortcut
- 13 Blower Speed Control
- 14 Left Temperature Control

Air Conditioning and Audio Systems

2

Auto Mode

AUTO

Set the target temperature required and then press the AUTO touch button to enable the auto mode function. In auto mode, the air distribution mode, blower speed and so on are automatically adjusted to reach and maintain the required temperature.

Manually adjust the air distribution mode or blower speed to exit auto mode. In this case the AUTO indicator will extinguish.

Note: To ensure the auto mode operates efficiently, all windows and the sunroof must be closed and the air inlet grille must be clear of obstructions. In addition, the A/C Auto control sensor should not be covered.

Cooling On/Off

Touch the cooling On/Off touch button to operate the cooling function.

Note: A small amount of water may remain in the air conditioner after usage, this may produce a peculiar smell. If this is a particular issue, it is recommended to

switch off the cooling function and run the blower for a while.

Air Recirculation Mode

Touch the air recirculation mode touch button to switch between air recirculation modes.



During internal recirculation, the air conditioning system circulates the air inside the car to meet the requirements of rapid cooling or heating, and at the same time, it can prevent the entry of traffic fumes.



During external circulation, the air conditioning system draws air from outside the vehicle to ensure fresh air enters the vehicle.



During automatic circulation, the air conditioning system automatically adjusts the internal recirculation or external circulation according to the situation.

Air Conditioning and Audio Systems

Note: Leaving the system in internal recirculation mode can cause the windscreen to mist. If this happens, turn on the defrost/demist mode.

Temperature Zone Control

Touch the temperature zone control touch button to switch between single or dual temperature zone control.

Single temperature zone control : When the button is illuminated , both zones are synchronised.

Dual temperature zone control : When the button is extinguished , both zones are independent.

Economy Mode





ECON

Touch the ECON touch button, the air conditioning system will enter Economy Mode. In Economy Mode, the air conditioning system will run at low energy consumption, so as to prolong the driving range.

Note: Selection of the ECON mode will impact situations that require maximum heating or cooling.

Air Distribution Mode

Select the corresponding Air Distribution Mode Touch Button as required to regulate the air distribution mode.

Control Interface	Air Distribution Mode
	Face Mode
	Face and Feet Mode
	Feet Mode
	Feet and Windscreen Mode
	Windscreen Mode

Face Mode : Directs air to the centre and side vents.

Air Conditioning and Audio Systems

Face and Feet Mode : Directs air to the centre, side and footwell vents.

Feet Mode: Directs air to the footwell vents.

Note: In this mode, a small amount of airflow will be directed to the side, windscreen/defrost and front side window vents.

Feet and Windscreen Mode: Directs air to the footwell, windscreen/defrost and front side window vents.

Note: In this mode, a small amount of airflow will be directed to the side vents.





Windscreen Mode: Directs air to windscreen/defrost and front side window vents.

Note: In this mode, a small amount of airflow will be directed to the side vents.

Intelligent Electric Sweeping Vent Control

Touch the intelligent electric sweeping vent control touch button as required to regulate the intelligent electric sweeping vent status of the driver side and the passenger side separately.

Note: The centre vents and upper side vents are equipped with intelligent electric sweeping vents.

Control Interface	Air Vent Mode
	To Person
	Avoid Person
	Sweeping
	Close the vent
	Smart Wind

To Person : Adjust the intelligent electric sweeping vent to direct airflow to the person.

Air Conditioning and Audio Systems

Avoid Person : Adjust the intelligent electric sweeping vent to avoid directing airflow to the person.

Sweeping : Adjust the intelligent electric sweeping vent to sweep.

Close the vent : Adjust the intelligent electric sweeping vent to be open or closed.

Smart Wind : Automatic control of intelligent electric sweeping vent status.

Note: Slide the air flow icon in the intelligent electric sweeping vent control bar in the control interface left or right to adjust the setting of the required side.

Temperature Control

Touch the temperature control touch button to regulate the temperature of the air supplied by the vents.

System On/Off

Touch the system On/Off touch button to switch the system on or off.

Blower Speed Control

Touch the blower speed control touch button to regulate the blower speed.

Defrost/Demist

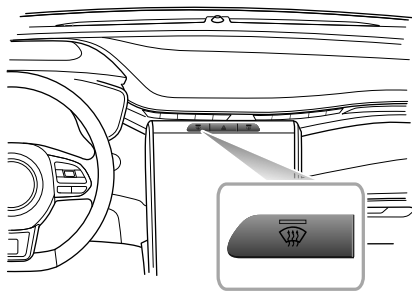

Press this button to operate the defrost/demist function, the indicator will illuminate. The system will automatically set itself to a preset temperature and blower

Air Conditioning and Audio Systems

motor speed to effectively clear the side windows and windscreen.

Press again to switch off. The indicator will go off and the system will return to the previous state

Whilst the defrost/demist is selected, operate the A/C on/off button to turn the compressor on/off; operate the air recirculation button to switch between internal recirculation and external circulation; operation of either of these functions will not affect the defrost/demist function; operation of any other air distribution modes will quit defrost/demist.

Heated Rear Window



The heating elements on the inside of the rear window are easily damaged. DO NOT scrape or scratch the inside of the glass. DO NOT stick labels over the heating elements.

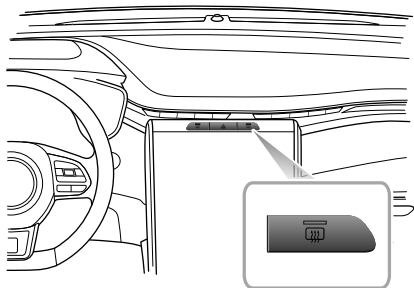

Press the Heated Rear Window Button to switch the function on or off. The button indicator illuminates when the function is on, and is extinguished when the function is off. The heated rear window features a timer function and will automatically switch off after a preset time. To continue to use the heated rear window, operate the button again.

Seats & Restraints

90 Seats

94 *Driver's Seat Personalisation
Function*

96 Seat Belts

107 *Airbag Supplementary Restraint
System*

116 *Child Restraints*

Seats & Restraints

Seats

Overview



To avoid personal injuries due to the loss of control, **DO NOT** adjust the seats while the car is moving.

An ideal position of the seat should make sure your driving position is comfortable, which allows you to hold the steering wheel with your arms and legs slightly bent and control all the equipment. Make sure your driving position is comfortable and enables you to maintain full control of the vehicle. Take care when adjusting the height of front seats - the feet of the rear passenger could become trapped when the seat is lowered.

DO NOT recline the front-seat backrest excessively. Optimum benefit is obtained from the seat belt with the backrest angle set to approximately 25° from the upright (vertical). The driver and front passenger seats should be positioned as far rearward as practical. A properly adjusted seat helps reduce the risk of injury from sitting too close to an inflating airbag.

Head Restraints



Adjust the height of the head restraint so that the top of it is in line with the top of the occupant's head. This location may reduce the risk of head and neck injuries in the event of a collision. **DO NOT** adjust or remove the head restraints while the car is moving.



DO NOT hang anything on any head restraint or head restraint rod.

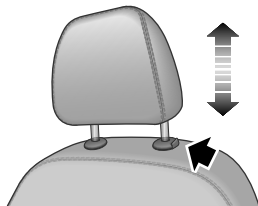

The head restraint is designed to prevent rearward movement of the head in the event of a collision or

Seats & Restraints

emergency braking, thereby reducing the risk of head and neck injuries.

When adjusting the front seat head restraints from a low to high position, pull the head restraint directly upward, and gently press it downward after it reaches the desired position to make sure that it is locked in position. To remove the head restraint, press and hold the guide sleeve button (as indicated by the arrow) on the left of the head restraint, then pull the head restraint upward to remove it.

When adjusting the front seat head restraints from a high to low position, press the guide sleeve button (as indicated by the arrow) on the left of the head restraint, and press the head restraint downward; release the button after it reaches the desired position, and gently press the head restraint downward to make sure that it is locked in position.

Front Seats

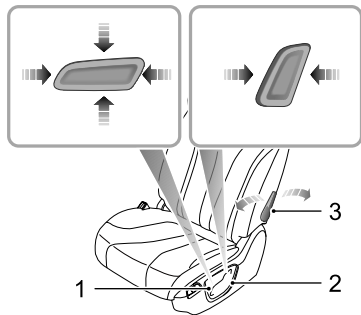

- **Forward/Rearward Adjustment**
Push the switch (1) forward or backward to move the seat forward/backward.
- **Cushion Height Adjustment ***
Pull the switch (1) upward or push downward to raise or lower the seat cushion.
- **Backrest Adjustment**

Seats & Restraints

Move the switch (2) forward/backward to adjust the backrest until it reaches the desired angle.

- Lumbar Support Adjustment *

Move the lever (3) to adjust the level of the lumbar support.

Rear Seats

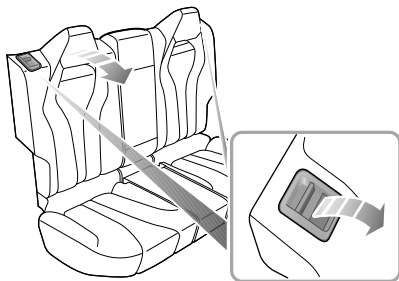

To increase the luggage space, the rear seat backrest can be fully folded forward. When folding the backrest,

completely insert the rear seat belt buckle into the corresponding slot first, then pull the respective control lever at the top of the seat backrest upwards and fold the seat backrest forward.

To return the backrest to an upright position, raise the rear seat backrest. When the desired upright position is reached, a 'click' will be heard. Ensure the backrest is locked in position.

Note: When returning the rear seat backrest to the desired position, make sure that the rear seat belt is not trapped.

Note: When the backrest of the front seat is reclined backward excessively, the folding of the rear seat is very likely to damage the back of the front seat, small storage compartment or head restraint of the rear seat.

Seat Ventilation Function *

The seat cushion and backrest of the front seats are provided with ventilation elements. After the vehicle is set to READY mode, access the air conditioning control

Seats & Restraints

interface and press the seat ventilation switch to control the ventilation function of the corresponding seat.

Front seat ventilation is available in three levels:

- High - All segments of the indicator illuminate.
- Medium - Two segments of the indicator illuminate.
- Low - Only one segment of the indicator illuminates.

Pressing the switch again at the 'Low' level will turn off the seat ventilation. The indicator will also extinguish.

Seat Heating Function



If bare skin is in contact with the heated seats for excessive periods of time, it may cause burns.

The seat cushion and backrest of front seats are provided with heating elements. After the vehicle is set to READY mode, access the air conditioning control interface and press the seat heating switch to control the heating function of the corresponding seat.

Front seat heating is set with three levels:

- High - All segments of the indicator illuminate.
- Medium - Two segments of the indicator illuminate.

- Low - Only one segment of the indicator illuminates. When the seat is heated to a high level for a long time, the system will automatically lower its level. Pressing the switch again at the 'Low' level will turn off the seat heating. The indicator will also extinguish.

IMPORTANT

- DO NOT cover the heated seats with blankets, cushions or other insulation type objects or materials.
- If the seat temperature has reached 42°C and continues getting hotter when using the seat heating system, please turn off the seat heating and contact an MG Authorised Repairer.
- Overuse of the driver's heated seat may cause drowsiness and could affect safety.

Seats & Restraints

Driver's Seat Personalisation Function

Driver Seat Welcome Function

The welcome function of the drivers seat is designed to allow the driver to get in and out the vehicle. The seat can automatically slide back and forth in a specific situation. This function is only available on vehicles equipped with memory seats. This function can be enabled or disabled through the entertainment system display.

When the welcome function of the seat is enabled, the convenience of this function will be reflected in the following situations:

- Getting out of the car : When the car is stopped, the START/STOP Switch is in the OFF position and the drivers door is opened. The seat will automatically slide back for a distance to provide a greater front space for the driver to get out of the car.
- Getting in the car: Unlock the car. Open the driver door. The seat will automatically slide back for a distance to provide a greater front space for the driver to get in the car. After the door is closed, the seat will automatically slide forward to the driving position set prior to exiting the car.

Seat Memory Function

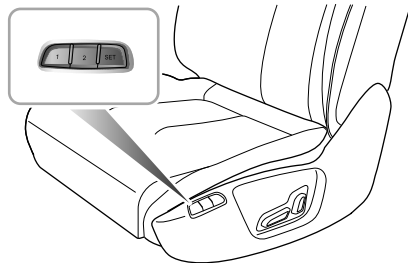

Vehicles with the memory function can provide a greater set of personalized settings for driving: this includes adjustment and memory of seat position and exterior rearview mirror angle (allowing the setting and saving of personalized settings for two drivers).

The seat position memory switch is on the outside of the driver seat (as illustrated). The setting methods are as follows:

- I Adjust the position and angle of the driver seat separately, then adjust the exterior rearview mirror angle (and the desired angle when reversing) (refer

Seats & Restraints

to "Rearview Mirrors" in "Instrument and Control" chapter for details).

- 2 Press SET and 1 buttons at the same time, the settings of the driving position for the current driver are then saved.

Repeat the above steps and press the SET and 2 buttons to complete the personalized settings of the driving position for the second driver.

To recall the memory position, select P (Park), then press and hold button 1 or button 2 corresponding to the desired driving position until the seat and the exterior rearview mirror glass are moved to the position stored. Release the button to stop the recall of memory function.

Note: If an object blocks the driver seat from reaching the preset position when the memory position is recalled, the function will stop working. If this happens, after removing the obstacle, press the appropriate memory button to try to recall the memory position again.

Seats & Restraints

Seat Belts



It is important that all seat belts are worn correctly. Always check that all passengers are wearing seat belts. DO NOT carry passengers that are unable to wear correctly positioned seat belts. Wearing seat belts incorrectly may cause serious injury or even death in the event of a collision.



Airbags can not replace seat belts. Airbags can only provide extra support when triggered, and not all traffic accidents will trigger airbags. Whether airbags are triggered or not, seat belts can reduce the risks of serious injury or death in accidents. Therefore, seat belts must be worn correctly.



NEVER unfasten a seat belt whilst driving. Serious injury or death may occur in the case of an accident or emergency braking.



This vehicle is equipped with a seat belt warning lamp to remind you to fasten your seat belt.

During driving, seat belts must be fastened, this is because:

- You can never predict if you will be involved in a collision accident and how serious it may be.
- In many cases of collision accidents, passengers with seat belts correctly fastened are well-protected, while passengers with seat belts not fastened suffer from serious injury or even death.

Therefore, all passengers must wear seat belts correctly, even during short-distance journeys.

Protection Provided by Seat Belts



It is of equal importance for passengers in the rear seat to fasten their seat belts correctly. Otherwise, passengers with seat belts not correctly fastened will be thrown forward in accidents, and will endanger themselves as well as the driver and other passengers.

Seats & Restraints

When the vehicle is in motion, the travelling speed of the occupants is identical to that of the vehicle.

In the event of a 'head on collision' or emergency braking, the vehicle may stop, but the occupants will carry on travelling until they come into contact with a stationary object. This object may be the steering wheel, dashboard, windscreen and other items.

A correctly fastened seat belt will eliminate this risk of injury. When the seat belt is worn correctly, it will lock automatically in collision accidents or emergency braking to reduce your speed together with the vehicle, so as to prevent the out-of-control movement which may cause serious injury to the driver and passengers.



Seats & Restraints

Wearing Seat Belts



Incorrectly worn seat belts could cause injury or death in the event of an accident.



Seat belts are designed for one person. DO NOT share seat belts.



DO NOT wrap a seat belt around you when holding a baby or child in your arms.



Remove any heavy coats or clothing when wearing a seat belt. Failure to do so can affect protection provided by the seat belt.



Seat belts should not be wrapped around hard or sharp objects such as pens, spectacles or keys to avoid additional injury to the users.



Seat belts cannot function correctly when the seats are reclined excessively. DO NOT drive when the seats are excessively reclined.

The seat belts fitted to your vehicle are designed for use by normal sized adults. This part of the literature refers to adult use. For advice on seat belt use with children, please see 'Children and Seat Belts'.

All seat belts are 3 point lap-shoulder belts.

In order to maintain effective protection, the passengers must sit in the correct orientation, feet placed on the floor in front of them, with an upright body (no excessive recline) and the seat belt correctly fastened.

Seats & Restraints

Fastening Seat Belts

Please follow the instructions below to fasten the seat belts correctly.

- 1 Adjust the seat correctly.
- 2 Hold the metal tab. Pull the seat belt out steadily over the shoulder and across your chest. Ensure there is no twist on the belt.

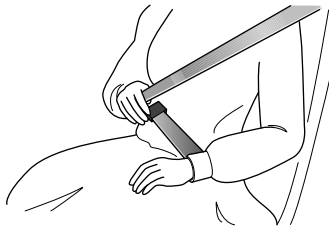

- 3 Insert the metal tab into the buckle until you hear a 'click'. This indicates the seat belt is securely locked.

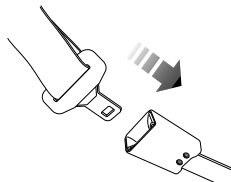

- 4 Remove any slackness in the belt by pulling up on the diagonal section of the belt.
- 5 To release the seat belt, press the red button on the buckle. The seat belt will retract automatically to its original place.

Seats & Restraints

IMPORTANT

- Always ensure the seat belt will not become trapped in the door aperture when closing the door. Damage will occur.
- Pulling the seat belt out too quickly may cause it to 'lock'. In this case, allow the seat belt to retract slightly and then pull it across your body slowly.
- If it is difficult to pull the seat belt out, it may be due to twisted webbing. If this is the case, fully extract the seat belt, remove the twist, and allow the seat belt to retract slowly.
- When using the rear seat belts please ensure they are fully retracted into the correct position to avoid jamming in the rear seat catches. Even if the seat belt is not completely smoothed, it is still required to be worn during driving, but the twisted part of the seat belt shall not contact the passenger. When this happens, please go to an MG Authorised Repairer for repair.

Correct Routing of the Seat Belts



Ensure the seat belt is correctly positioned on the body, NEVER cross the neck or abdomen. NEVER pass the seat belt behind the back or under the arms.

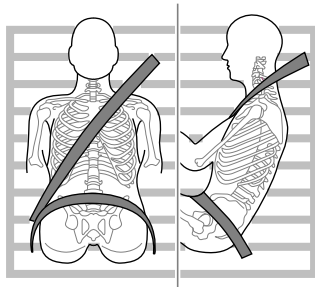

When wearing seat belts, the lap belt section should be positioned as low as possible across your hips. NEVER cross the abdomen. In the event of a collision, the lap belt can apply a force on the hips and reduce the possibility of

Seats & Restraints

3

you slipping under the lap belt. If you slip under the lap belt, the belt will apply force on your abdomen, which may cause serious or fatal injuries. The diagonal section of the belt should cross the middle of the shoulder and the chest. In the event of emergency braking or collision, the diagonal section of the belt will be locked. NEVER position a seat belt across your neck, across the body under your arms or behind your back.

To ensure that the seat belts always provide maximum protection, ensure the belt is flat, not loose and contacts the body.

Upper Anchorage Height Adjustment



During driving, DO NOT adjust the height of the seat belt.



Ensure the fixing point of the seat belt is adjusted to the proper height and locked before driving, otherwise injury or even death may occur in collision accidents.

The vehicle is equipped with an adjustable upper fixing point on the driver and passenger seat belts. Adjust the height so that the diagonal section of the belt crosses the middle of the shoulder. The seat belt should be positioned away from the neck and head and in a manner where the occupant cannot slide under the belt. Incorrect positioning will reduce the efficiency of the seat belt in the event of a collision or emergency braking.

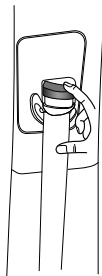

Adjusting the seat belt fixing point correctly.

- I Hold the seat belt.

Seats & Restraints

- 2 Press release button and move the height adjuster to the desired position. Move the adjuster by pushing the slider.
- 3 After moving the adjuster to the desired position, release the button and try to move the adjuster downward to determine whether it is locked in place. The adjuster must be locked in place prior to use.

Seat Belts During Pregnancy

Wearing correctly positioned seat belts will provide protection for both mother and unborn child in the event of a collision or emergency braking.



The diagonal section of the seat belt should pass across the chest as normal, the lap section of the belt should pass below the belly, low and snug on the hip bones. NEVER position the belt on or above the belly.

Please consult your physician for further details.

Seat Belts and Disabilities

It is a legal requirement that all occupants wear seat belts. This includes people with disabilities.

Depending upon the disability, consult your physician for further details.

Seats & Restraints

Children and Seat Belts

! *Proper protection measures must be taken for children during driving.*

For safety reasons, children must travel in a child restraint device fixed to the rear seat.

Infants

! *Only recommended child restraints suitable for the age, height and weight of the child should be used.*

! *NEVER carry a child or infant with your arms during driving. When collision accidents occur, the weight of the child will produce so great of a force that you will not be able to hold on to the child. The child will be thrown forward and suffer serious injury or even death.*

The seat belts fitted to your vehicle are designed for adults. They are not suitable for children. In the event of an accident or collision, the children are not secure. It could cause death or serious injury.

Infants **MUST** use a suitable child restraint device. Please consult the child seat manufacturer's guidelines when selecting the correct seat. Follow the manufacturer's instructions on installation. Please refer to "Child Restraints" in this chapter for more details.

Older Children

! *NEVER share a seat belt amongst children. In the event of an accident or collision, the children are not secure. It could cause death or serious injury.*

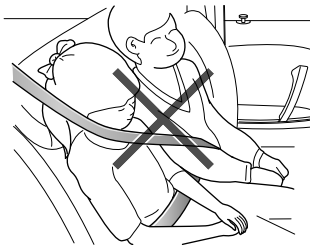

Seats & Restraints

As children grow and become older/larger it will get to the stage when they no longer require child seat restraints. At this point they will require use of the vehicle standard seat belt. Please ensure the seat belt is correctly positioned on the body of the child.

When fastening a seat belt for a child always check it for correct positioning. Adjust the height of the seat belt to ensure the shoulder belt is kept away from the child's face and neck. Position the lap belt across the hips as low as possible, and tighten adequately. Correct positioning means that the seat belts can pass the applied force to the strongest part of the child's body in accidents.

If the shoulder belt is too close to the child's face or neck, it may be necessary to use a child booster cushion (always ensure that it meets any relevant laws or standards).

Seat Belt Pre-tensioners



The seat belt pre-tensioners will only be activated once and then **MUST BE REPLACED**. Failure to replace the pre-tensioners will reduce the efficiency of the vehicle's restraint system.



If the pre-tensioners have been activated, the seat belts will still function as restraints, and must be worn in the event that the vehicle remains in a drivable condition. The seat belt pre-tensioners should be replaced at the earliest opportunity by an MG Authorised Repairer.

The vehicle is fitted with seat belt pre-tensioners. These are designed to retract the seat belts and work in conjunction with the airbags in the event of a severe collision. They are designed to retract the seat belt and 'secure' the occupant in the seat.

The airbag warning light on the instrument pack will alert the driver to any malfunction of the seat belt pretensioners.(see 'Warning Lights and Indicators' in the 'Instruments and Controls' chapter).

The seat belt pre-tensioners can only be activated once. After activation they must be replaced. This may also involve replacement of other SRS components. Please refer to 'Replacing Airbag System Parts'.

Seats & Restraints

IMPORTANT

- Seat belt pre-tensioners will not be activated by minor impacts.
- The removal or replacement of a pre-tensioner must be carried out by the technicians trained by the manufacturer.
- 10 years from the initial date of registration (or installation date of a replacement seat belt pre-tensioner), some components will need to be replaced. The appropriate page of the Service Records must be signed and stamped once the work has been completed.

Seat Belt Checks, Maintenance and Replacement

Seat Belt Checks



Split, worn or frayed seat belts may not function correctly in the event of a collision, if there are any signs of damage, replace the belt immediately.



Always ensure the red release button on the seat belt buckle is pointing upwards to ensure easy release in the event of an emergency.

Please follow the instructions below to check the seat belt warning lamp, seat belt, metal tab, buckle, retractor and fixing device regularly:

- Insert the seat belt metal tab into the corresponding buckle and pull seat belt webbing close to the buckle quickly to check that the belt clasp locks.
- Hold the metal tab and pull the seat belt forward quickly to check that the seat belt reel locks automatically, preventing the webbing from extending.

Seats & Restraints

- Fully extract the seat belt and visibly examine for twists, fraying, splits or worn areas.
- Fully extract the seat belt and allow to return slowly to ensure continual and complete smooth operation.
- Visibly examine the seat belt for missing or broken components.
- Ensure the seat belt warning system is fully functional.

If the seat belt fails any of the above tests or inspections, contact an MG Authorised Repairer immediately for repairs.

Seat Belt Maintenance



DO NOT attempt to remove, install, modify, disassemble or dispose of the seat belts. Have any necessary repairs carried out by your MG Authorised Repairer. Inappropriate handling may lead to incorrect operation.



Ensure no foreign or sharp objects become lodged in the seat belt mechanisms. DO NOT allow liquids to contaminate the seat belt buckle. This could affect the buckle engagement.

Seat belts should only be cleaned with warm soapy water. **DO NOT** use any solvent to clean the seat belt. **DO NOT** attempt to bleach or dye the seat belt. It may weaken the seat belt. After cleaning, wipe with a cloth and allow to dry. **DO NOT** allow the seat belt to fully retract before it is completely dry. Keep seat belts clean and dry.

If there are contaminants accumulated in the retractor, the retraction of the seat belt will be slow. Please use a clean and dry cloth to remove any contaminants.

Replacing Seat Belts



Collision accidents may damage the seat belt system. The seat belt system may not be able to protect users after damage, which may result in serious injury or even death. After an accident, seat belts should be checked and replaced as needed immediately.

Seat belts should not require change after minor collisions, however, some other parts of the seat belt system may require attention. Please consult an MG Authorised Repairer for advice.

Seats & Restraints

Airbag Supplementary Restraint System

Overview



*The airbag SRS provides **ADDITIONAL** protection in a severe frontal impact only. It does not replace the need, or requirement to wear a seat belt.*



The airbags together with the seat belts provide optimum protection for adults, but it is not the case for infants. The seat belt and airbag systems in the vehicle are not designed for protecting infants. The protection required by infants should be provided by child restraints.

The Airbag Supplementary Restraint System generally consists of:

- Front Airbags (fitted to the centre of the steering wheel and dashboard above the glove compartment)
- Seat Airbags (fitted to both side of the driver seat squab and the outer side of front passenger seat squab)

- Side Head Impact Protection Airbags (fitted behind the headlining)

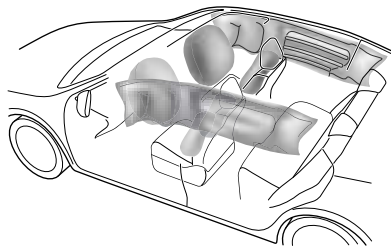

3

In the corresponding place where airbags are fitted, there is a warning sign stating 'AIRBAG'.

Airbag Warning Light



The airbag warning light is located in the instrument pack. If this lamp does not extinguish or

Seats & Restraints

illuminates during driving, it indicates that there is a failure in the SRS or seat belt. Please consult an MG Authorised Repairer at the earliest opportunity. An SRS or seat belt fault may mean the components may not be deployed in the event of an accident.

Airbag Deployment



Front seat passengers should not place feet, knees or any other part of the body in contact with, or in close proximity to a front airbag.



To minimise the risk of accidental injury from inflating airbags, seat belts should be worn correctly at all times. In addition, both driver and front seat passenger should adjust their seat to provide sufficient distance from the front airbags. If side airbags/side head impact protection airbags are fitted, both the driver and front seat passenger should be seated to maintain sufficient distance from the upper part of the body to the sides of the vehicle. This will ensure maximum protection when the side airbags/side head impact protection airbags are deployed.

Seats & Restraints



When airbags are deployed, children without proper protection may suffer from serious injury or even death. DO NOT carry children in the arms or on the knees during traveling. Children should wear seat belts suitable to their age. DO NOT lean out of windows.



An inflating airbag can cause facial abrasions and other injuries if the occupant is too close to the airbag at the time of its deployment.



DO NOT affix or place any objects on, or adjacent to the airbags. This may affect the airbag passage or create projectiles that may cause injury or serious harm in the event of airbag deployment.



After deployment the airbag components become very hot. DO NOT touch any airbag related components. It may cause burns or serious injury.



DO NOT knock or strike the position where airbags or related parts are located, so as to avoid accidental airbag deployment which may cause serious injury or even death.

In the event of a collision, the airbag control unit monitors the rate of deceleration or acceleration induced by the collision, to determine whether the airbags should be deployed. Airbag deployment is virtually instantaneous and occurs with considerable force, accompanied by a loud noise.

Provided the front seat occupants are correctly seated and with seat belts properly worn, the airbags will provide additional protection to the chest and facial areas in the event of the car receiving a severe frontal impact.

Seat airbags and side head impact protection airbags are designed to offer additional protection to the side of the body facing the impact, if a severe side collision occurs.

Seats & Restraints

IMPORTANT

- Airbags can not protect lower body parts of passengers.
- Airbags are not designed for rear collision, minor frontal or side impacts, or if the vehicle overturns; nor will it operate as a result of heavy braking.
- Deployment and retraction of the frontal and side airbags takes place very quickly and will not protect against the effects of secondary impacts that may occur.
- When an airbag inflates, a fine powder is released. This is not an indication of a malfunction, however, the powder may cause irritation to the skin and should be thoroughly flushed from the eyes and any cuts or abrasions of the skin.
- After inflation, front and side airbags deflate immediately. This provides a gradual cushioning effect for the occupant and also ensures that the driver's forward vision is not obscured.

Front Airbags



NEVER use a rearward facing child restraint on a seat protected by an ACTIVE AIRBAG in front of it. DEATH or SERIOUS INJURY to the CHILD can occur. Refer to 'Disabling the Passenger Airbag'.



Front seat passengers should not place feet, knees or any other part of the body in contact with, or in close proximity to a front airbag.



In extreme cases, driving on very uneven surfaces may cause airbag deployment. Please take extra care when driving on uneven roads.

Airbags are designed to deploy during serious impacts, the following conditions may cause airbag deployment.

- A frontal collision with unmovable or non deformable solid objects at a high speed.
- Conditions that can cause serious chassis damage, such as a collision with kerbstones, road edges, deep ravines or holes.

Seat Airbags



The structure and material of the seat is critical to the correct operation of side airbags. Therefore, please DO NOT fit seat covers which may affect side airbag deployment.

In the event of a serious side impact, the inner side airbag of the driver seat and the relevant side (only the affected side) airbag will deploy.

- The airbag will be deployed in the event that the side of the vehicle is impacted with a solid object or another vehicle.

Side Head Impact Protection Airbags

In the event of a serious side impact, the relevant side curtain airbag will deploy (only the affected side).

- The side curtain airbag will be deployed in the event that the side of the vehicle is impacted with a solid object or another vehicle.

Conditions in Which Airbags Will Not Deploy

The deployment of airbags does not depend on the vehicle speed, but on the object that the vehicle hits, angle of impact and the rate at which the car changes speed as a result of a collision. When the impact force of collision is absorbed or dispersed to the vehicle body, airbags may not deploy; however, airbags may sometimes deploy according to impact condition. Therefore, the deployment of airbags shall not be judged based on the severity of vehicle damage.

Front Airbags

Under certain conditions the front airbags may not be deployed. Some examples are listed below:

- The impact point is not central to the front of the vehicle.
- The impact is not of sufficient force (the impact is with an object that is not solid, such as a lamp post or central barriers).
- The impact area is high (collision with the tailgate of a truck).
- Impacts to the rear or side of the vehicle.

Seats & Restraints

- The vehicle rolling over.
- Frontal collision at an angle with guard bars.

Seat Airbags and Side Head Impact Protection Airbags

Under certain conditions the seat side and side head airbags may not be deployed. Some examples are listed below:

- Side impacts at certain angles.
- Light side impacts such as with a motorcycle.
- Impacts that are not central to the side of the vehicle, either too far toward the front compartment or the loadspace.
- The vehicle rolling over.
- Frontal collision at an angle with guard bars.
- The angled impact is not of sufficient force (the impact is with an object that is not solid, such as a lamp post or central barriers).
- The impact is not of sufficient force (with another vehicle, stationary or moving).
- The impact is from the rear of the vehicle.

Disabling the Passenger Airbag



The Passenger Airbag should only be disabled when a rear facing child seat is fitted to the front passenger seat.



When an adult is seated in the front passenger seat, ensure that the airbag is switched on.

The passenger airbag switch is located in the entertainment system. Press the switch to control the status of the passenger airbag. The passenger airbag status light in the entertainment system indicates the status of the passenger airbag.



- When the passenger airbag is disabled, the OFF indicator light illuminates.



- When the passenger airbag is enabled, the ON indicator light illuminates for a period of time.

IMPORTANT

- If the OFF and ON indicator lights illuminate together, or the light is inconsistent with the passenger airbag statement, please contact an MG Authorised Repairer immediately.

Service and Replacement of Airbags

Service Information



DO NOT install or modify the airbag. Any changes to the vehicle structure or airbag system wiring harness are strictly prohibited.



Changes to vehicle structure are prohibited. This may affect the normal operation of the SRS.



DO NOT allow these areas to be flooded with liquid and DO NOT use petrol, detergent, furniture cream or polishes.



If water contaminates or enters the SRS, it may cause damage and affect deployment. In this case contact an MG Authorised Repairer immediately.

To prevent damage to the airbag SRS, the following areas should be cleaned sparingly with a damp cloth and upholstery cleaner ONLY:

Seats & Restraints

- Steering wheel centre pad.
- Area of dashboard containing the passenger airbag.
- Area of roof lining and front pillar finishers which enclose the side head impact protection modules.

If the airbag warning lamp fails to illuminate, stays on, if there is damage to the front or side of the vehicle, or the airbag covers show signs of damage, contact an MG Authorised Repairer immediately.

IMPORTANT

- The removal or replacement of an airbag module should be carried out by an MG Authorised Repairer.
- After 10 years from the initial date of registration (or installation date of a replacement airbag), some components will need to be replaced by an MG Authorised Repairer. The appropriate page of the Service Records must be signed and stamped once the work has been completed.

Replacing Airbag System Parts



Even if the airbag does not deploy, collisions may cause damage to the SRS in the vehicle. Airbags may not function properly after damage, and cannot protect you and other passengers when a second collision occurs, which may cause serious injury or even death. To ensure that the SRS can function properly after a collision, please go to an MG Authorised Repairer to check airbags and repair as necessary.

Airbags are designed to be used only once. Once the airbag is deployed, you must replace SRS parts. Please go to an MG Authorised Repairer for replacement.

Disposal of Airbags

When your vehicle is sold, ensure that the new owner knows the vehicle is equipped with airbags, and is aware of the replacement date of any SRS components.

If the vehicle is scrapped, the undeployed airbags may have potential risks, therefore, before the disposal, they must be

Seats & Restraints

deployed safely in a certain environment by a professional from an MG Authorised Repairer.

Seats & Restraints

Child Restraints

Important Safety Instructions about Using Child Restraints

It is recommended that children below the age of 12 years old should be seated on the rear seat of the vehicle, in a child restraint system appropriate to the children's weight and size. Infants less than 2 years old should be restrained in an infant child restraint system.

It is recommended that a child restraint system that complies with UN ECE-R44 or ECE-R129 standard are fitted in this vehicle. Check markings on the child restraint system.

There are a number of child restraint systems available of different types and specifications. For optimum protection, it is recommended that you choose restraint systems appropriate to the child's age and weight.

It is important to comply with installation instructions supplied by the child restraint manufacturer and that the child restraint system is properly secured to the vehicle. Failure to follow these instructions may cause death or

serious injury to the child in an event of a sudden stop or accident.

- All occupants, including children must wear seat belts or use an appropriate child restraint.
- MG strongly recommends that children under 12 years of age or less than 1.5 metres tall should use the appropriate child restraint fitted to the rear seat.
- Only one child can be carried in any one restraint.
- Do not put the child on the lap or in arms when sitting in any seat.
- Ensure the seat is locked in position when installing a child seat or restraint.
- If installing a rear facing child restraint to the rear seat, the corresponding front seat should be adjusted forward; if installing a forward facing child restraint to the front seat, you may need to remove its headrest.
- Never let your child stand or kneel on the seat during driving.
- Always ensure the child is seated correctly in the child restraint.
- The ways in which seat belts are used have a great influence on the maximum protection offered by the

Seats & Restraints

seat belt. You must comply with the child restraint manufacturer's instructions on proper use of seat belts. If seat belts are not properly fastened, a minor traffic accident may also lead to injury.

- Child restraints that are not fitted correctly may move and injure other occupants in the event of an accident or emergency braking. Therefore, even if there is no infant or child in the child restraint, it also should be fitted properly and securely in the vehicle.

Warnings and Instructions on Use of Child

Restraint on Front Passenger Seat



NEVER use a rearward facing child restraint on a seat protected by an **ACTIVE AIRBAG** in front of it. **DEATH** or **SERIOUS INJURY** to the **CHILD** can occur.



In cases where there is a need to install a rear facing child restraint on the front passenger seat, deactivate the front passenger airbag function, or severe injury or even death can occur.



Once the child restraint is removed from the front passenger seat, reactivate the front passenger airbag.



When installing a child restraint on the front passenger seat, move the front passenger seat as far rearward as possible.



Use one child restraint per child.

Seats & Restraints

Please study the safety warning label on the sun visor. Where possible always install child restraints on the rear seat. If it is necessary to install a child restraint on the front seat, please observe the warnings above.

Children's Safety and Side Airbags



Children should not be allowed in areas where airbags may be deployed. There is a risk of serious injury.



Only recommended child restraints suitable for the age, height and weight of the child should be used.



DO NOT place any items in areas where airbags may be deployed. There is a risk of serious injury.

In the event of a side collision, the side airbags can provide better protection for the passenger. However, when the airbag is triggered a very strong expansion force is generated. If the passenger's seating position is not

correct, the airbags or items in the side airbag deployment area may cause injury.

When the correct child restraint is used to secure the child properly in the rear seat and the child's seating position is correct, there is enough space between the child and the side airbag deployment region for the airbag to deploy without any hindrance, and thus provide the best protection.

Seats & Restraints

How to Fasten a Child Restraint

Secured Using 3 Point Lap Diagonal Belts



Please DO NOT put the rear facing child restraint in the front passenger seat. This may cause serious injury or even death.

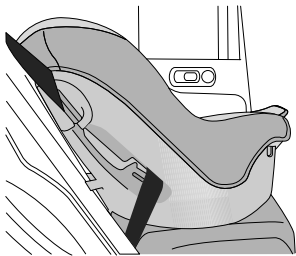

It is recommended that children should always be seated in the rear of the vehicle in a child restraint or restraint system, and fastened with 3 point, lap diagonal seat belts.

ISOFIX Child Restraint Systems



The ISOFIX anchorages in the rear seat are designed for use with ISOFIX systems only.



Child restraint anchorages are designed to withstand only those loads imposed by correctly fitted child restraints. Under no circumstances are they to be used for adult seat belts, harnesses, or for attaching other items or equipment to the vehicle.

Note: *When installing and using any child restraint system, always follow the manufacturer's instructions.*

Note: *The rear seats fitted to this vehicle are equipped with the ISOFIX interface (as indicated by the arrow in the following image). These are designed to connect to an ISOFIX child seat.*

Seats & Restraints

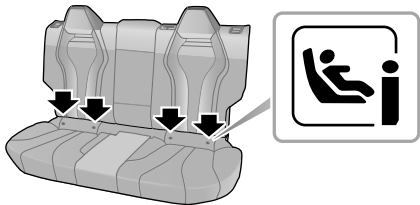

- 1 Fasten vehicle-approved ISOFIX child restraint systems to the mounting brackets.
- 2 When using ISOFIX mounting brackets for seat mounting, universally approved child restraint systems for ISOFIX may be used.

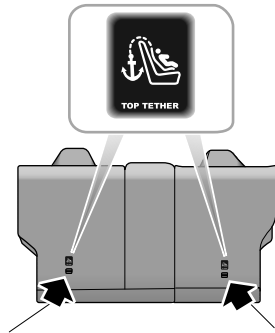

- 3 To fasten the top tether strap of the child restraint system, route the tether strap under the head restraint and attach to the anchorage hook, being careful not to twist the strap. If not using ISOFIX lower anchorages, using the seatbelt, complete the installation in line with the child restraint manufacturers instructions.

Note: When using seat mounting, universally approved child restraint systems, the top tether must be used.

Seats & Restraints

- 4 After installation apply suitable force to ensure the restraint is securely fastened.

Seats & Restraints

Approved Child Restraint Groups and Positions

It is recommended that a child restraint system that complies with UN ECE-R44 or ECE-R129 standard are fitted in this vehicle. Check markings on the child restraint system.

Approved Child Restraint Positions (for non ISOFIX Child Restraints)

Mass Group	Seating Positions			
	Front Passenger		Rear Outboard	Rear Middle
	With Front Passenger Airbag OFF Switch			
	Airbag ON	Airbag OFF		
0 group (less than 10 kg)	X	X	U	X
0+ group (less than 13 kg)	X	X	U	X
I group (9 ~ 18 kg)	X	X	U	X
II group (15 ~ 25 kg)	X	X	U	X
III group (22 ~ 36 kg)	X	X	U	X

Note: Description of letters in the table:

U = Suitable for universal child restraint systems approved for this mass group;

X = Seat position not suitable for child restraint systems in this mass group.

Seats & Restraints

Approved Child Restraint Positions (for ISOFIX Child Restraints)

Seating Position		Mass group categories			
		0 group	0+ group	I group	
		Rear facing		Forward facing	Rear facing
		Up to 29 lbs(13 kg)		20–40 lbs(9 ~ 18 kg)	
Front Passenger Seat	Size Class	Not ISOFIX equipped			
	Seat Type				
Rear Outboard Seat ISOFIX	Size Class	C,D,E ¹	A,B, BI ¹	C,D ¹	
	Seat Type	IL	IL,IUF	IL	
Rear Centre Seat	Size Class	Not ISOFIX equipped			
	Seat Type				

Note: IL Suitable for particular ISOFIX child restraint systems of the semi-universal category. Please consult child restraints systems suppliers' vehicle recommendation lists;

IUF Suitable for ISOFIX forward facing child restraint systems of the universal category approved for use in this mass group and ISOFIX size class;

¹. The ISOFIX size class for both universal and semi-universal child seat systems is defined by the capital letters grade A ~

Seats & Restraints

G. These identification letters are displayed on the ISOFIX child seat;

Table of I- Size child seats

The table gives a recommendation for which I- Size child seats are appropriate for which locations, and for what size of child.

The child seat must be approved in accordance with UN Reg R129.

Type of child seat	Front passenger seat	Rear outboard seats	Rear centre seat
I- Size child restraint systems	X	I-U	X

Note: I-U Suitable for use with forward and rear facing I- Size child restraint systems.

X Not suitable for use with I- Size restraint systems.

Note: Kidfix III S is recommended for a 6 years old child. The lap belt guide (secure guard) and the side impact extensions should be used. The side impact extensions should be extended to the outermost when in use. Nania Dream is recommended for a 10 years old child.

Seats & Restraints

Group 0/0+ Child Restraint



When the front passenger airbag is active, never place a rear facing child restraint on the front passenger seat. Severe injury or even death can occur.

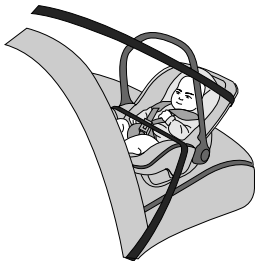

Child restraints that can be adjusted to the lying position are most suitable for infants who are lighter than 10 kg (normally for those younger than 9 months) or those who are lighter than 13 kg (normally for those younger than 24 months).

Group I Child Restraint



When the front passenger airbag is active, never place a rear facing child restraint on the front passenger seat. Severe injury or even death can occur.

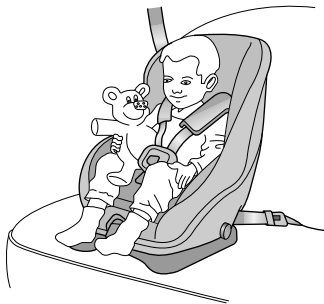

Backward/forward child restraints are most suitable for infants whose weight is 9 ~ 18 kg (normally for those older than 9 months and younger than 4 years old).

Seats & Restraints

Group II Child Restraint



The diagonal section of the seat belt should pass across the shoulder and upper body, away from the neck. The lap section of the belt should pass across the hips, away from the abdomen.



The combination of child restraint and 3 point lap diagonal seat belt is most suitable for children whose weight is 15 ~ 25 kg (normally for those older than 3 years old and younger than 7 years old).

Group III Child Restraint



The diagonal section of the seat belt should pass across the shoulder and upper body, away from the neck. The lap section of the belt should pass across the hips, away from the abdomen.



The combination of child booster seat and vehicle 3 point lap diagonal seat belt is most suitable for children whose weight is 22 ~ 36 kg and whose height is below 1.5 m (normally for those about 7 years old or those older than 7 years old).

Starting & Driving

128 Keys

131 Child Proof Locks

132 Alarm Systems

140 Starting and Stopping Power System

144 Pedestrian Alert Control System

145 Economical and Environmental Driving

*147 Charging and Discharging
Requirements*

163 Electric Drive Transmission

177 Brake System

*191 Stability Control System (SCS) and
Traction Control System (TCS)*

192 Driver Attention Warning System

194 Adaptive Cruise Control System

203 Parking Aid System

206 Rear Driving Assistance System

*213 Tyre Pressure Monitoring System
(TPMS)*

214 Driving Assist System

230 Load Carrying

Starting & Driving

Keys

Overview



Please keep the spare key in a safe place - not in the car!



It is recommended that spare keys are not kept on the same key ring.



The smart key contains delicate circuits and must be protected from impact and water damage, high temperature and humidity, direct sunlight and the effects of solvents.

Your vehicle is equipped with two smart keys. Each one contains a back up mechanical key blade. This will operate the driver door mechanical lock.

The smart keys supplied are programmed to the security system on the car. Any key that is not programmed to the car will not operate the keyless entry function or the vehicle immobiliser.

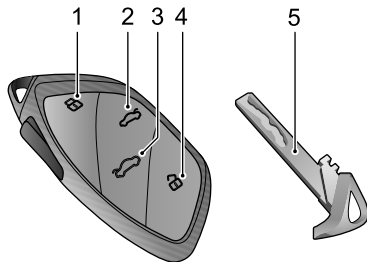

- | | | | |
|---|----------------|---|-----------------|
| 1 | Lock Button | 2 | Tailgate Button |
| 3 | Bonnet Button | 4 | Unlock Button |
| 5 | Mechanical Key | | |

The smart key only works within a certain range. Its working range is sometimes influenced by the key battery condition, physical and geographical factors. In consideration of safety, after you lock your vehicle using

Starting & Driving

the smart key, please recheck to ensure the vehicle is locked.

If your key is lost/stolen or broken, a replacement can be obtained from an MG Authorised Repairer. The lost/stolen key can be deactivated. If the lost key is found, an MG Authorised Repairer can reactivate it.

Note: Any key made independently outside of the MG Authorised Repairer Network may not allow your car to enter READY mode, and may affect the safety of your car. To obtain a suitable key replacement, it is recommended that you contact an MG Authorised Repairer.

Note: When operating your vehicle with the smart key, avoid placing it near any devices with strong radio interference (such as notebook computers and other electronic products). The normal function of the key may be affected.

Replacing the Battery

Please use the picture guide to replace the smart key battery if any of the following conditions occur:

- The smart key locking/unlocking function range is reduced;
- The immobilisation warning lamp on the instrument pack flashes.

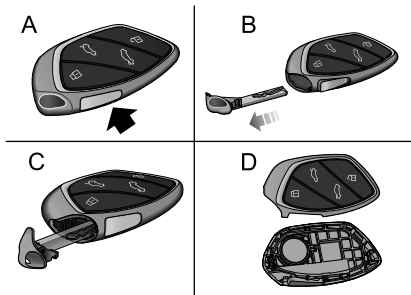

- 1 Press the button (A) on the smart key .
- 2 Remove the backup mechanical key (B) in the arrowed direction.

Starting & Driving

- Using the mechanical key or a suitable flat bladed tool, insert the tool into the side of the key (C). Carefully prise off the battery cover.
- Separate the upper and lower casings carefully (D).
- Remove the battery from the slot.
- Put the new battery in the slot, and make sure it is in full contact with the slot.

Note: *Make sure that the polarity of the battery is correct ('+' side facing down).*

Note: *It is recommended to use a CR2032 battery.*

- Refit the cover and press tightly, ensuring the gap around the cover is even.
- Refit the mechanical key.
- Set the vehicle power system to READY to resynchronise the key with the vehicle.

IMPORTANT

- Use of an incorrect or inappropriate battery may damage the smart key. The new replacement's rated voltage, sizes and specifications must be the same as the old one.
- Incorrect fitting of the battery may damage the key.
- Disposal of the used battery must be strictly in accordance with relevant environmental protection acts.

Child Proof Locks



NEVER leave children unsupervised in the car.

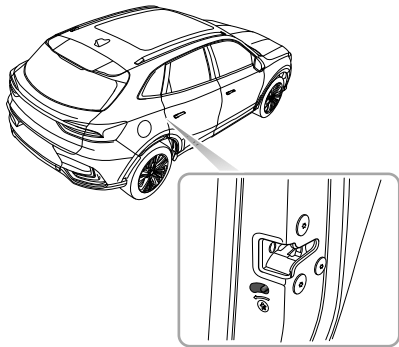

- Move the lever to the unlock position in the reverse direction of the arrow to disable the child proof lock. With the child proof locks engaged, the rear doors cannot be opened from inside the car, but can be opened from outside the car.

Steps for enabling or disabling the child proof locks are as follows:

- Open the rear door at the corresponding side. Move the child proof lock lever to the lock position in the direction of the arrow to engage the child proof lock;

Alarm Systems

Your car is fitted with a body anti-theft system and power immobilisation system. To ensure maximum safety and operation convenience, we strongly recommend you to carefully read this chapter to fully understand the activation and deactivation of anti-theft systems.

Power Immobilisation

Power Immobilisation is designed to safeguard the vehicle from theft. The power immobilisation system can only be deactivated to start the car by using the matched key.

Press the START/STOP Switch. Once a valid key is detected in the vehicle, the immobilisation system will be deactivated automatically.

If the message centre displays "Smart Key Not Detected" or "Put Key Into Backup Position" or the power immobiliser system warning lamp illuminates, please put the smart key into the back-up position (refer to "Alternative Starting Procedure" in "Starting and Stopping the Power System" section), or try to use the spare key. If the car can still not be started, please contact an MG Authorised Repairer.

Body Anti-theft System

Locking and Unlocking

When the vehicle is locked, the indicator lamps will flash three times as confirmation; when it is unlocked, the indicator lamps will flash once.

Operation of Door Lock System (Key)

Key Locking

- Using the remote key to lock: press the lock button on the key to lock the car after closing the doors, bonnet and tailgate.
- Using the mechanical key to lock: remove the mechanical key from the smart key and pull the driver's side door handle, insert the key into the driver door lock and turn clockwise to lock the car.

Key Unlocking

- Using the remote key to unlock: press the unlock button on the key to unlock the car.
- Using the mechanical key to unlock: remove the mechanical key from the smart key and pull the driver's

Starting & Driving

side door handle, insert the key into the driver door lock and turn counterclockwise to unlock the car.

Find My Car

After the vehicle has been left in a locked condition in excess of 2 minutes, pressing the lock button again on the remote key will enable the Find My Car function. This function will identify the car by means of an audible and visual alert. Pressing the Lock button on the handset again will suspend this operation. Pressing the Unlock button will cancel this operation.

Note: *If the START/STOP Switch is not placed in the ACC or ON/READY position or the remote key unlock is not activated within about 15 seconds after the vehicle is unlocked with the mechanical key, the immobiliser alarm will be triggered.*

Note: *If no panels are opened within about 30 seconds after the vehicle is unlocked by using the remote key, all doors will automatically re-lock.*

Operation of Door Lock System (Keyless)

The keyless entry system can lock and unlock the doors or open the tailgate as long as you carry the smart key and approach the car.

IMPORTANT

The smart key must be within 1.5 metres of the vehicle for the keyless system to operate correctly

Keyless Locking

After switching the vehicle power system to OFF using the START/STOP Switch and exiting the car, press the door handle button once before moving away from the car to lock all doors and the tailgate (no need to press the lock button on the key). Note, this will also arm the alarm and immobilise the vehicle.

Keyless Unlocking

Press the button on the front door handle once to unlock the car, then pull the door handle to open the door.

Note: *When the vehicle is locked, if you are within the smart key range and operate the door handle button, but carry out no further action, after 30 seconds*

Starting & Driving

the vehicle will automatically re-lock itself to remain secure.

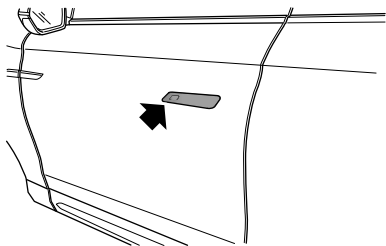

IMPORTANT

After the door is locked by using the key, press the button on the door handle to unlock the car. If the car cannot be unlocked or locked normally, seek an MG Authorised Repairer.

Door handle ejects automatically

After the vehicle is locked for about 30 seconds, if the smart key is detected close to the driver's door, the vehicle will automatically unlock and the door handle will eject automatically. This function can be set on the entertainment display.

Note: This function is temporarily disabled when the vehicle's low voltage battery is low.

Note: After the door handle is ejected automatically, if no other operation is carried out for a preset period of time, the vehicle will re-lock automatically. After that, the automatic ejecting function of the door handle is temporarily disabled, it is reactivated after the vehicle is unlocked and relocked or an ignition cycle operation or the door is opened and closed.

Note: When using this function, please do not put the key in the car.

Mislock

If the driver's door is not fully closed when the smart key lock button is pressed, or the vehicle power system has

not been switched OFF, the vehicle horn will sound once, indicating a mislock. In this case, none of the doors will lock, the alarm system will not be armed and the direction indicator lights will not flash.

If a locking operation is performed when the driver's door is closed but the passenger's door or bonnet and tailgate are not fully closed, the vehicle horn will sound once, indicating a mislock. In this case, the 'partial arming' attributes of the body anti-theft system will enable (all fully closed doors, bonnet or tailgate apertures will be protected, but an open aperture will not!). As soon as the open aperture is closed, the system will automatically revert to an armed state.

Anti-Theft Alarm Sounder

If the anti-theft alarm has been triggered, the car horn will sound continuously. Press the UNLOCK button on the key, the anti-theft alarm will be deactivated.

Interior Lock and Unlock Switch

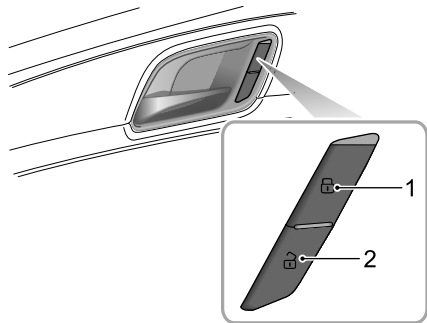

- 1 Lock Switch
- 2 Unlock Switch

When the anti-theft alarm system is not set, press the lock switch (1) to lock all doors; press the unlock switch (2) to unlock all doors.

Starting & Driving

Note: *If the anti-theft alarm system is set, pressing the lock/unlock button will not lock/unlock the doors but will trigger the alarm system.*

If the doors, bonnet and tailgate are closed, press the interior lock switch. The yellow indicator on the interior lock switch illuminates.

If a mislock is caused by the non-driver door, tailgate or bonnet, press the interior lock switch. The yellow indicator on the interior lock switch illuminates.

Interior Door Handles

Use the interior door handles to open the door:

- 1 Pull the interior door handle once to unlock the door.
- 2 Pull the interior door handle again to open the door.

Speed Lock

All the doors will be locked automatically when the road speed exceeds 15 km/h.

Automatic Unlock

When the vehicle power system is switched to the OFF position, all the doors will be unlocked automatically.

Electric Tailgate



Before operating the electric tailgate, ensure no persons, animals or obstructions are within the direct vicinity of the tailgate. They may become trapped between the tailgate and a vehicle or the tailgate and an obstacle. Ensure any items carried in the rear of the vehicle have adequate clearance from the tailgate when closing.

The electric tailgate will only operate whilst the vehicle has Park (P) selected.

Whilst the electric tailgate is operating the system will emit an audible warning.

Starting & Driving

Electric Tailgate Open/Close Mode

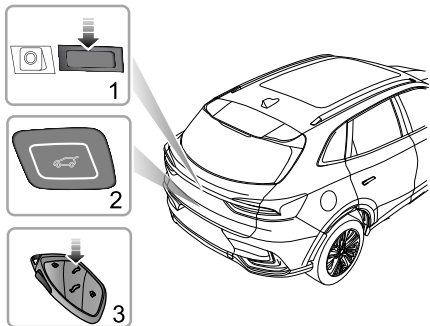

The electric tailgate can be opened or closed using the following methods:

- **Open/Close from outside** : When the vehicle is unlocked or the matched key appears within 1 m range around the tailgate. Press button 1 to open the tailgate, press button 2 to close.
- **Open/Close by smart key** : When START/STOP Switch is in the OFF position, press and hold the tailgate

button 3 on the smart key to automatically open or close the tailgate.

- **Open/Close from inside** : Touch the button in the Infotainment screen to open/close the tailgate.

Note: In certain conditions where the vehicle has been stopped or parked on an extreme incline, the tailgate may not be electrically opened or fully closed due to the change of centre-of-gravity position.

Note: If the tailgate fails to fully open to its preset height, or fully close, carry out a manual operation to close the tailgate. This will restore the electric tailgate operation.

Note: During manual operation of the electric tailgate, avoid violent or rapid operation. Failure to follow these instructions may result in damage to the power tailgate system.

Kicking Sensor *

You can open/close the tailgate using the kicking function if the matched key appears within 1 m range around the tailgate. (START/STOP Switch must be OFF and all doors closed).

Starting & Driving

Note: When using the kicking function, please stand at the center of the rear bumper and repeatedly place and remove your foot (1) under the bumper in a quick kicking motion (2). The tailgate will automatically open or close respectively.

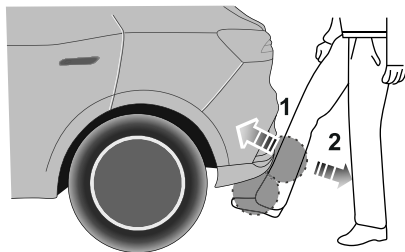

Note: The kicking function can be set through the Infotainment screen. In order to avoid the tailgate

opening by mistake, please disable the kicking function when washing or repairing the vehicle.

Note: In some cases, you should use other methods to open or close the tailgate if the kicking function is unresponsive.

Anti-pinch Function

Whilst opening the tailgate: In cases where an object that interferes with the tailgate operation is detected, the tailgate will stop opening and return to a safe angle automatically where the obstructions can be removed.

Whilst closing the tailgate: In cases where an object that interferes with the tailgate operation is detected, the tailgate will stop closing and return to a safe angle automatically where the obstructions can be removed.

Note: If the anti-punch function has been activated multiple times in a brief period, the system will suspend the electric opening/closing function for protection. In this situation, the tailgate can be fully closed once manually so as to reset the function of the electric tailgate.

Note: *If the tailgate is frequently operated in a short period, the system thermal protection may be triggered, causing the electric opening/closing function to be temporarily unavailable. Operation will be suspended for a preset time limit.*

Setting Opening Height for Electric Tailgate

Users can set the opening height of the electric tailgate as needed by using the Close button on the tailgate or Infotainment screen. The electric tailgate controller will record the new opening height.

Note: *The opening height setting values of the electric tailgate must be between 40% and 100% of its total stroke.*

Setting mode 1:

- 1 Place the tailgate to the desired setting height, and keep it stationary.
- 2 Press and hold the Close button on the tailgate for a minimum of 3 seconds. A buzzer will sound to indicate the successful setting.

Setting mode 2:

Turn on the Infotainment system, enter the height setting interface for the electric tailgate, and move the height setting slider to desired position.

Note: *If an electric tailgate system failure occurs, a relevant warning message "Power Liftgate System Fault" and icon will be displayed in the message centre of the instrument pack. Please consult an MG Authorised Repairer.*

Starting and Stopping Power System

START/STOP Switch



The keyless START/STOP Switch is located in the fascia to the right of the steering column. It is a push button style switch. To operate the switch the smart key must be inside the vehicle.

The operational status displays are as follows:

Indicator Off (OFF)

If the switch has not been operated and there are no indicators illuminated, the power system is OFF. The power seats and electric door mirrors remain operational.

Yellow Light (ACC)

Pressing the START/STOP Switch without the footbrake being applied whilst the vehicle power system is OFF will place the system in the ACC state. This will illuminate the yellow indicator in the switch button. The ACC position allows operation of certain ancillaries such as power windows.

Green Light (ON/READY)

- Whilst in the ACC state, pressing the START/STOP Switch without the footbrake being applied will place the system in the ON state. The green indicator will illuminate. This will allow the remaining electrical systems to operate.
- Pressing the START/STOP Switch with P selected and the footbrake applied will place the vehicle in the READY state, the green indicator will illuminate and the word READY will appear in the instrument panel information display. This indicates that all electrical

systems will operate and the vehicle is ready to be driven.

Note: *Whilst in the OFF state, if the driver exits the vehicle, leaving the smart key inside and closes the driver's door, subsequent re-opening of the driver's door will cause a buzzer to sound and display a warning message in the instrument pack message centre to indicate that the key is still in the car.*

Note: *To remove the electronic shift control lever from P, the vehicle must be in an ON/READY state and the footbrake applied.*

If your car is subject to strong radio signals, the keyless entry and start systems may suffer from interference and not function correctly. Please see the 'Alternative Starting Procedure'.

READY Mode

Setting the power system to READY mode:

- 1 Ensure all unnecessary electrical loads (inc AC) are switched off.
- 2 Ensure the parking brake is applied. (refer to "Brake System" of this chapter)
- 3 Ensure P or N is selected.
- 4 Press the brake pedal.
- 5 Press the START/STOP Switch (do not hold the button in, release immediately).
- 6 The green indicator will illuminate and READY will be displayed in the instrument pack message centre.

Starting & Driving

IMPORTANT

- In extremely low temperatures, if the power system fails to enter READY mode on 3 successive attempts (Ready indicator of the power system fails to illuminate), it is recommended to turn off the power supply and wait for rescue.
- Do not leave the START/STOP Switch in an ACC or ON/READY state for long periods of time. Excessive use of electrical equipment may lead to a discharged battery.
- The vehicle is fitted with an anti-theft system. Independently sourced keys may not allow vehicle entry and system power up. Any new keys will require programming using the manufacturers software.

Alternative Starting Procedure

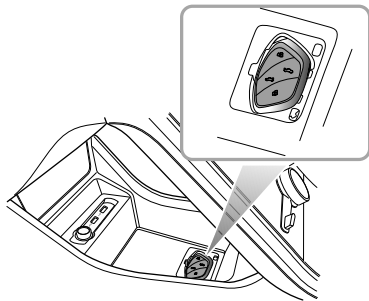

If the car is located in an area where there are strong radio signals causing interference or the smart key battery condition is low, please use the following steps to attempt to start the car:

- 1 Remove the pad of the centre console cubby box and pry open the cover of the key slot, then place the smart key in the key slot with the buttons facing upward - as shown in the illustration.

Starting & Driving

- 2 Ensure P or N is selected, press the brake pedal and then press the START/STOP Switch to activate the power system.

If the vehicle power system cannot be changed after the car has left the area of strong radio interference or had the smart key battery replaced, please consult an MG Authorised Repairer.

IMPORTANT

Application scope of alternative starting procedure:

- The Alternative Starting Procedure should only be required if the smart key battery is very low or empty.
- Once the vehicle has been removed from the area of excessive radio interference, the keyless entry and Start Stop systems should return to normal.

- 2 Using the electronic shift control knob, select (P) and apply the parking brake - please check that the parking brake is applied.
- 3 Press the START/STOP Switch to shut down the power system.

Note: Please observe the parking brake warning light displayed in the instrument pack message centre confirming that the parking brake has been applied before exiting the vehicle.

4

Switching the Power System OFF

Setting the power system to OFF:

- 1 After bringing the car to a halt, ALWAYS maintain brake pedal application.

Pedestrian Alert Control System

In order to improve safety, your car is fitted with a Pedestrian Alert System. When the vehicle is travelling at a low speed, the system controls a speaker that sounds to remind pedestrians in the vicinity of your presence.

Sound Strategies

The speaker sounds when all of the following conditions are met:

- 1 The vehicle is READY;
- 2 The Pedestrian Alert System is fault free;
- 3 During acceleration, the vehicle speed is less than 30 km / h; during deceleration, the vehicle speed is less than, or equal to 25 km / h.

Economical and Environmental Driving

Running-in

The brakes and tyres need time to 'bed-in' and adjust to the demands of everyday motoring. During the first 1500 km, please avoid heavy braking where possible.

Economic Driving and Maintenance

The following are some suggestions on saving power and extending the life of the vehicles.

- Maintain the correct tyre pressure; low pressures will result in accelerated tyre wear and increase power consumption.
- Do not carry unnecessary weight. Heavy loads will increase the vehicle load resulting in higher power consumption.
- Avoid continuous acceleration or deceleration. A stop-go driving style will consume more power.
- Avoid unnecessary stopping and braking, maintain a steady speed and attempt to anticipate traffic lights.

Note: Keep an appropriate distance from other vehicles to avoid emergency braking and reduce brake pad wear.

- Avoid traffic congestion and jam areas as much as possible.
- Anticipating obstructions and slowing down well in advance avoids the need for unnecessary acceleration and harsh braking. A smooth driving style can reduce power consumption.
- Do not ride the brake pedal. This can cause premature wear, overheating and increased power consumption.
- Maintain an appropriate speed on the highway. Higher speeds use more power. An appropriate speed can save power.
- Maintain the correct wheel alignment. Avoid collisions with the kerb and reduce speed on uneven road surfaces. An out of specification wheel alignment will not only lead to excessive tyre wear, but also increases the vehicle load and power consumption.
- Avoid driving on mud or beaches. This will prevent corrosion of the vehicle underside.
- Maintain the vehicle in accordance with MG recommendations. .

Starting & Driving

Note: To extend the life of all components and reduce operating costs, regular MG Approved maintenance is needed.

- Use of electrical equipment will reduce the power available from the battery. Whilst it is essential to maintain a comfortable interior environment, excessive use of a system such as A/C will increase power consumption and reduce the vehicle range.

Driving in Special Environment

Driving in Rain or Snow



Emergency braking, accelerating and steering on slippery roads will reduce the vehicle's handling performance and grip.

- When it is raining the windows may fog, reducing visibility (Use the Air-conditioning demist function).
- Grip will be reduced, so please drive carefully.
- Avoid aquaplaning (the effect of a film of water between the tyres and the road). This will effect steering and braking performance.

Driving through Water

Avoid driving through floods after heavy rain, which may lead to serious damage to the vehicle.

Charging and Discharging Requirements



Under normal circumstances it is strongly recommended that you use a slow charging method, avoid constant or regular use of rapid chargers.



Prior to using any charging equipment please inspect the sockets, plugs and cables for any damage. DO NOT use any equipment that shows signs of misuse or damage.



It is recommended that the charging cable be connected to the charging device before connecting to the vehicle and charging commences.



DO NOT attempt to switch the vehicle power system to READY during charging.



After charging completion, switch off the charger (where necessary), disconnect the cable from the vehicle, fit the waterproof blanking plugs, close the charging point door. If necessary you can then disconnect the cable from the charger (where applicable).



Whilst charging the car on rainy days, where possible, please avoid connecting the charger during torrential rain or storms. If excessive water is evident around the charging plugs please use a suitable cloth to dry the area as best possible before removing the waterproof blanking plugs and connecting the charging cables.



DO NOT touch the charging connector or charging plug when your hand is wet.



DO NOT stand in water or snow when connecting or disconnecting the charging cable.

Starting & Driving



DO NOT attempt to charge when the charging connector and plug are wet.



Always keep the charging connector and charging plug in clean and in a dry condition. Be sure to keep the charging cable in a condition where there is no water or moisture.



Only use the correct charger for charging the electric vehicle. Using any other charger or connector configuration may cause failure.



Take care not to drop the charging connector. This could result in damage.



STOP charging or discharging immediately if you find anything abnormal, such as sparks, burning or smoke.



Always hold the charging connector handle or plug when connecting or removing the charging cable, if you pull the cable itself (without using the handle), the internal wires may disconnect or get damaged. This may lead to electric shock or fire.



High voltage charging or discharging equipment can cause interference with electronic medical devices. When using medical electrical devices such as pacemakers, please consult your doctor about whether charging or discharging your electric vehicle will impact the operation of the device. In some instances, electromagnetic waves that are generated from the charger can seriously impact medical electric device operation.



NEVER use a high powered jet wash directly on the charger door or to clean around the charge point.

Charging Your Vehicle at Home

Whilst your MG has been supplied with a home charging kit, it is essential that you check with a qualified electrician that the infrastructure of your property will support the charging equipment. Please seek qualified advice that your current electrical supply and circuits will support the requirements of the charging equipment.

Installed Charging Points

Various companies will supply and install charging points to your property, MG insist that only qualified reputable suppliers and installers are used - failure to have the correct equipment installed by a qualified professional may result in overloaded circuits and fire.

Home Charging Guide

ONLY use certified approved equipment.

ONLY use qualified suppliers and installers.

When the battery is fully charged, disconnect the cable plug from the vehicle socket - if it is necessary to interrupt the charging of the vehicle, isolate the power supply first , then disconnect the vehicle plug.

NEVER allow water or fluids to enter or contaminate your charger or vehicle charging sockets.

NEVER use damaged charging points, equipment or sockets.

STOP charging immediately if you see anything unusual, smell something burning or see sparks.

ALWAYS follow the operating instructions supplied with your charging equipment.

Note: The charging point and power supply infrastructure must be installed and serviced by suitable qualified personnel from an approved installation company using only the materials recommended by them.

Starting & Driving

Charging and Medical Condition Awareness



High voltage charging equipment can create areas of strong electromagnetic interference, this may cause operational issues with electronic medical devices.

When using medical electrical devices such as pacemakers or cardioverter defibrillators (ICD's), please consult your doctor about whether charging or discharging your electric vehicle will have an impact on the operation of the device. In some instances, electromagnetic waves that are generated from the charger can seriously impact medical electric device operation.

Note: There are no cautions issued about medical devices when the car is not charging or discharging. It is perfectly safe for individuals fitted with pacemakers or cardioverter defibrillators to drive or ride in the vehicle.

Charging Port

The charging port is located behind the charging port door located rear right of the vehicle. It is incorporated into the master locking system.

To open the door, ensure the vehicle is unlocked, press the charging port door and release - the door will open to reveal the waterproof plug covers.

Remove the plug covers to reveal the combined charging port.

Starting & Driving

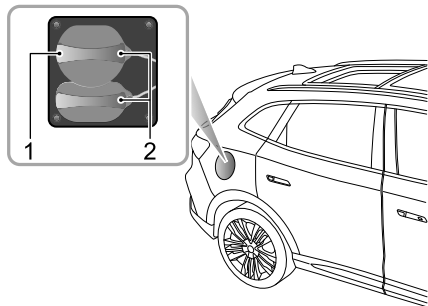

- 1 Slow and Fast Charge Port - 7 Pin - Type 2 Plug
- 2 Rapid Charge Port - 7 Pin and 2 Pin - CCS Type Plug

The upper plug covers the 7 pin slow/fast charging socket (1). The lower plug covers the rapid charging socket (2).

Note: *In order to use the rapid charger socket, both waterproof plug covers will require removal.*

After charging, refit the waterproof plug covers, close the charging port door, push the door fully home until the latch locates.

ALWAYS ensure that any excess water is removed from the port area before connecting any charging device.

Charging Port Electronic Lock

In order to prevent the charging connector and cable being disconnected inadvertently during charging, the charging socket features an electronic locking mechanism.

The electronic lock is activated as soon as the vehicle begins charging, and remains in a locked state until the charging is finished or interrupted.

Whilst the charging cable is connected DO NOT attempt to remove the plug.

Manually Releasing the Charging Port Lock in Emergency Situations

The vehicle features an emergency release device for the charging port lock.

To access the manual release, remove the trim plate covering the service access hole on right side of boot - see picture.

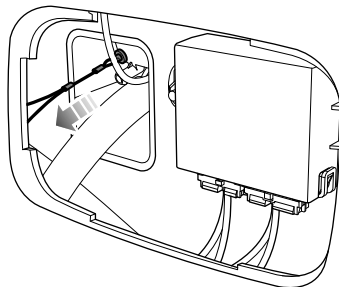

Pull the release cable handle, remove the connector plug whilst maintaining tension on the cable this will release the locking device.

Rapid Charging

Note: Please read any equipment operating instructions carefully prior to using the rapid charging station. Each type of charger may use different instructions.

Note: The cable of the charging plug should be shorter than 30 m.

If you have any doubts, please seek professional assistance.

Rapid Charging Safety Precautions

- Before connecting the rapid charger, switch the vehicle power system OFF and wait 10 seconds.

Note: If at any time during the charging process you should want to check the state of charge, please switch the vehicle power system to the ON position. The high voltage battery state of charge will be displayed in the message centre in the instrument pack.

Slow Charging

Note: Carrying out a full slow charge is the only way for the high voltage battery to reach the optimal equilibrium state (equalisation charge).

High voltage battery chargers are available with various power outputs. Chargers with outputs of up to 11kW are generally considered as slow chargers, larger than 11kW are considered as fast chargers and rapid chargers are available in AC or DC outputs. Generally the AC chargers are rated at 43kW and the DC chargers at 50kW plus.

Charging times are dependent on charger output.

To carry out an equalisation slow charge, it is recommended that the charger output does not exceed 11kW.

Note: Chargers of up to 7kW power output are supplied via standard household single phase power. Any chargers that are rated above this, 11kW for example, will require a 3 phase power supply.

Starting & Driving

AC Charging Points

IMPORTANT
Please ensure that only charge points that meet IEC 61851 and IEC 62196 are used to connect to your vehicle.

voltage battery state of charge will be displayed in the message centre in the instrument pack.

Using an AC charging device:

- 1 Ensure the vehicle power system is OFF and all doors are closed.
- 2 Open the charging port door, remove the waterproof plug cover from the 7 pin charging plug connector.
- 3 Plug the cable from the charger point into the vehicle. Lock the vehicle.
- 4 On completion of the charge , shut off the power, unlock the vehicle and disconnect the plug from the vehicle.
- 5 Ensure the charge socket is free from debris, fit the waterproof plug cover. Close the charging point door.

Note: If at any time during the charging process you should want to check the state of charge, please switch the vehicle power system to the ON position. The high

Residential Charging

During the charging operation the vehicle power system must be OFF. Carry out the following procedure to charge the vehicle:

- 1 Ensure the vehicle power system is OFF and all doors are closed.
- 2 Open the charging port door, remove the waterproof plug cover from the 7 pin charging plug connector. Ensure the surroundings are clean, dry and free from debris.
- 3 Connect the 7 pin charging plug to the socket on the vehicle.
- 4 Connect the charging device plug to the domestic electricity supply. Lock the vehicle.
- 5 On completion of the charge, shut off the power, unlock the vehicle, disconnect the charging cable from the vehicle, and then the domestic plug.
- 6 Ensure the charge socket is free from debris, fit the waterproof plug cover. Close the charging point door.

Note: *If at any time during the charging process you should want to check the state of charge, please switch the vehicle power system to the ON position. The high voltage battery state of charge will be displayed in the message centre in the instrument pack.*

Starting & Driving

Charging Information

At the beginning of the charging process, the following information will be displayed within the instrument pack message centre.



- 1 Current time
- 2 High voltage battery pack status
- 3 Driving range
- 4 Charging status

Note: The information displayed on the instrument pack may be different based on vehicle configuration.

Equalisation Charging

Equalisation charging means that after a normal charging process the battery management system will enter a mode where it will attempt to equalise the charge of every battery cell.

If an equalisation charge has not been carried out for some time, the message centre in the instrument pack will display 'Please slow charging the car to balance the battery'. Please refer to 'Slow Charging' in the 'Starting and Driving' section.

On average it takes at least 11 hours (single phase power) or 8 hours (three phase power) to complete a charge that includes the equalisation charge.

Note: *Ambient temperatures have an effect on charging times. It may take longer to complete a charge when the ambient temperatures are low.*

Charging Times

Charging times of the high voltage battery can vary depending upon numerous factors, these include: current capacity, charging mode, ambient temperature and device type/power.

Rapid Charging Time

Rapid chargers will vary in power output, on average it will take approximately 40 - 60 minutes to charge the high voltage battery up to 80% (80% displayed in IPK) using an average rapid charger.

Note: *Ambient temperatures have an effect on charging times. It may take longer to complete a charge when the ambient temperatures are low or high.*

Slow Charging Time

On average it takes approximately 10 hours (single phase power) or 7 hours (three phase power) to charge the high voltage battery from low battery warning to 100% (charge quantity can be checked using the instrument pack).

- At low temperatures the charging time will be extended.

Starting & Driving

- If an equalisation charge has not been conducted for a long time the required charge time will be extended.
- An equalisation charge must be carried out prior to using the car after a long period of storage or non use. In these cases the charging time will be extended.

Note: The slow charging notes above relate to using an AC charging device. Use of the slow charging device supplied with the car using a domestic power supply can increase the charging times by up to 3 times.

Starting & Driving

Indicative Charging Times

Note: *These times are only a guide.*

Rapid charging		From alarm status (the high voltage battery low warning displayed in the instrument pack message centre) to 80%, it takes almost 40 minutes.		
Slow charging	Residential electricity	From alarm status (the high voltage battery low warning displayed in the instrument pack message centre) to 100% (the high voltage battery state of charge displayed in the instrument pack message centre), it takes almost 30 hours.	From alarm status (the high voltage battery low warning displayed in the instrument pack message centre) to 100% (the high voltage battery state of charge displayed in the instrument pack message centre) and equalisation, it takes almost 31 hours.	It takes approximately 32 hours to complete an equalisation charge for first use after the vehicle has been parked or stored for a long time.
	AC charging station (single phase power, approx 7kW)	From alarm status (the high voltage battery low warning displayed in the instrument pack message centre) to 100% (the high voltage battery state of charge displayed in the instrument pack message centre), it takes almost 10 hours.	From alarm status (the high voltage battery low warning displayed in the instrument pack message centre) to 100% (the high voltage battery state of charge displayed in the instrument pack message centre) and equalisation, it takes almost 11 hours.	

Starting & Driving

Slow charging	AC charging station (three phase power, approx 11kW)	From alarm status (the high voltage battery low warning displayed in the instrument pack message centre) to 100% (the high voltage battery state of charge displayed in the instrument pack message centre), it takes almost 7 hours.	From alarm status (the high voltage battery low warning displayed in the instrument pack message centre) to 100% (the high voltage battery state of charge displayed in the instrument pack message centre) and equalisation, it takes almost 8 hours.	It takes approximately 9 hours to complete an equalisation charge for first use after the vehicle has been parked or stored for a long time.
---------------	--	---	--	--

Discharging

The vehicle is equipped with a discharge function, this can convert the high voltage DC power in the high-voltage battery pack into 220V domestic AC power.

This discharge function can be realized by using a discharge kit.

Note: Users have the opportunity to purchase the discharge kit from an MG Authorised Repairer.

To use the discharge function, follow the instructions below:

- 1 Unlock the vehicle and access the AC charging port (the charging port is also the discharging port).
- 2 Insert the discharge gun connector into the discharge port socket. When fully connected the discharge port indicator will illuminate blue.
- 3 Access the energy management interface in the entertainment display screen, ensure the cut-off power of discharge is set. After setting, click the start discharging button, the electronic lock will lock the discharge gun in place and the vehicle will enter the discharge state. At this time, do not attempt to

remove the discharge gun using force, this will damage the locking mechanism.

- 4 The user is able to click the stop discharging button in the entertainment display screen to stop the discharge, or stop the discharge after the power is discharged to the set cut-off value. At this time the electronic lock will automatically be released and the discharge gun can be removed.
- 5 Make sure there is no debris or foreign matter in the charging port, fit the charging port cover and close the charging point door.

Note: After the vehicle starts discharging, if the entertainment display goes off, the vehicle will still maintain the discharging condition.

Note: During discharge, the START/STOP switch can be placed in the "ON" position to check the current power status and driving range of the high-voltage battery pack via the instrument cluster.

Note: During the discharge process, the user can still set the discharge power cut-off point.

Starting & Driving

Note: *During discharge, the vehicle cannot be placed in “READY” mode.*

Note: *Using the discharge function will reduce the driving range of the vehicle.*

IMPORTANT

- Before beginning the discharge operation, check the condition of the discharge connector and gun.
- If it is necessary to use the discharge function on wet days, please pay particular attention in protecting the discharge port area and discharge gun from water, rain or snow.
- In cases of abnormal phenomena such as peculiar smells, smoke emission or overheating etc during the discharge process, the electrical circuit **MUST** be disconnected immediately and the discharge operation stopped.

Electric Drive Transmission

Instructions

The following information is very important. Please read carefully before use:

- The electric drive transmission consists of a high voltage unit. **DO NOT** touch any drive components unless you have the correct training and qualifications.
- Before setting the vehicle power system to ON, please ensure that P or N is selected, the parking brake **AND** footbrake are applied.
- When the vehicle power system is **READY**, use the shift control knob to select your required gear.
- Release the parking brake but maintain footbrake application until you are ready to manoeuvre. On a flat road, once you release the footbrake you will begin to move. Slowly apply the accelerator to increase your speed.

Gear Shift Control

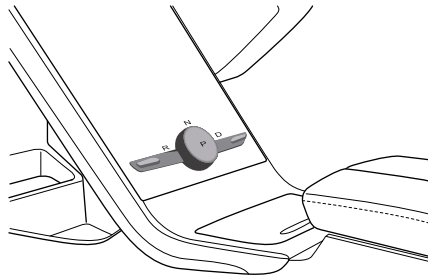

Note: The highlighted letters in the information centre indicate the selected gear.

Starting & Driving

Shift Control Knob - Operation



DO NOT press the shift control knob whilst driving.

The shift control knob defaults to the middle steady-state. The clockwise or counterclockwise positions are non-steady states using spring loaded momentary switches.

Shift Control Knob - Position



DO NOT turn the shift control knob to either P or R from the D position whilst driving or whilst the vehicle is in motion. This will cause severe damage to the electric drive transmission or cause an accident.

- P Park

When the shift control knob is in this position, the electronic parking brake is applied. Only select this gear when the vehicle is stationary.

Note: The electronic parking brake system must be released via the EPB switch. See “Electronic Parking Brake (EPB)” in the “Brake System” section.

If the vehicle speed is below 2 km/h, the shift control knob can be pressed to select and engage P.

If the vehicle speed is below 2 km/h and the START/STOP Switch is operated to power the vehicle OFF, P will automatically be selected and engaged.

If the vehicle speed is below 2 km/h, the footbrake released, the driver seat belt unfastened and the driver door opened, P will automatically be selected and engaged.

The initial gear position after powering the vehicle will be P. When switching to the R, D or N positions the footbrake MUST be applied.

- R Reverse

Select this gear only when the vehicle is stationary and you wish to drive backwards.

Depress the footbrake, turn the shift control knob counterclockwise to the end and release. The spring

Starting & Driving

loaded shift control knob will return to a central position and the vehicle will enter Reverse.

- N Neutral

Select this gear when the vehicle is stationary (for example, waiting for traffic lights).

When in Park, depress the footbrake, turn the shift control knob clockwise or counterclockwise to the first non-steady state position and release. The spring loaded shift control knob will return to a central position and the vehicle will enter Neutral.

Whilst D is selected, turn the shift control knob counterclockwise to the first non-steady state position and release. The spring loaded shift control knob will return to a central position and the vehicle will enter Neutral.

In Reverse, turn the shift control knob clockwise to the first non-steady state position and release. The spring loaded shift control knob will return to a central position and the vehicle will enter Neutral.

- D Drive

This is used for normal driving.

Whilst in Park, depress the footbrake, turn the shift control knob clockwise to the end and release. The spring loaded shift control knob will return to a central position and the vehicle will enter Drive.

In R or N, turn the shift control knob clockwise to the end and release. The spring loaded shift control knob will return to a central position and the vehicle will enter Drive.

When the vehicle is stationary and has remained in Neutral for more than 2 seconds. Please depress the footbrake, turn the shift control knob clockwise to the end and release. The spring loaded shift control knob will return to a central position and the vehicle will enter Drive.

For safety reasons ALWAYS apply the footbrake when shifting between R and D positions.

Kick-down



The drive wheels may skid when kick-down is activated on road surfaces with low adhesion. This may lead to the vehicle sliding out of control.

Starting & Driving

With D gear selected, pressing the accelerator pedal all the way down in one motion (also known as Kick-down) will provide better acceleration performance during overtaking. Under certain conditions, it will allow the electric drive transmission to shift to a lower gear immediately, and provide fast acceleration.

Vehicle Start-off

The vehicle can only be switched to a READY mode with P or N selected and the footbrake applied.

After selecting your desired gear position, after waiting a very short time for the electrical drive transmission to engage and releasing the brake pedal, you should press the accelerator to start driving.

Starting & Driving

Driving on Hills



In cases where a short stop on a hill is required, such as a traffic jam, DO NOT momentarily apply the accelerator to prevent “roll back”. This could cause the electric drive transmission to overheat or even system damage.

Hill Start

In cases of a hill start, the start assist function of the electronic parking brake (EPB) can be used to prevent the vehicle from rolling backwards. For details of this function, please refer to “Electronic Parking Brake (EPB)” in “Brake System” section.

Models fitted with Hill Hold Control can use this function to assist hill starts. For details on the hill hold control system, please refer to “Hill Hold Control” in “Brake System” section.

Note: *The aid of these functions cannot defy the laws of physics. DO NOT drive the vehicle beyond its physical limitations. Loss of control will still occur.*

Driving Mode - 2WD*



Please avoid switching between Driving Modes whilst driving. This may divert the driver's attention away from road conditions and cause an accident.

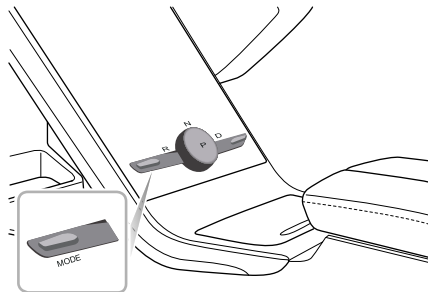

The driver can manually select four driving modes by operating the MODE switch on the electronic shifter in

Starting & Driving

the infotainment display: WINTER Mode, ECO Mode, NORMAL Mode and SPORT Mode.

The information centre will display: WINTER, ECO, NORMAL, SPORT.

Toggle the MODE switch forward or backward to switch between the driving modes.

In each of the driving modes, the control system uses different control strategies for output control.

- **WINTER Mode**

WINTER Mode is used for driving under special road conditions.

- **ECO Mode**

ECO Mode optimises energy consumption. This will provide the best results regarding the range of the vehicle.

- **NORMAL Mode**

NORMAL Mode combines economy and performance to meet the driving requirements of most drivers.

- **SPORT Mode**

SPORT Mode concentrates on providing more power to enhance the performance.

It is recommended to choose the Sport Mode when driving on special road conditions such as mountain roads .

Every time the vehicle power system is cycled, and the system then set to READY mode, the driving mode defaults to NORMAL mode.

In different driving modes, the power delivery, steering and air conditioning system varies. Please refer to the table below.

Driving Mode	Power Mode	Steering Mode	A/C Mode	Brake Mode
WINTER	ECO	Normal	ECO	Normal
ECO	ECO	Normal	ECO	Normal
NORMAL	NORMAL	Normal	Normal	Normal
SPORT	SPORT	Dynamic	SPORT	SPORT

Starting & Driving

Note: Whilst WINTER or ECO mode is selected, the A/C will operate in a low energy consumption state to provide an increase in vehicle power. To set the A/C, please refer to the infotainment display.

Note:

Ambient lighting can be linked with the driving mode. It will switch between different colours in different driving modes. When the ambient lighting is in the CUSTOM state, it will not be affected by the driving mode. To set the ambient lighting, please refer to the infotainment display.

Driving Mode - AWD*



Please avoid switching between Driving Modes whilst driving. This may divert the driver's attention away from road conditions and cause an accident.



For a car equipped with the all-wheel drive system, all the wheels **MUST** only use tyres of the same specification from the same tyre manufacturer under normal driving conditions, otherwise the driveability and driving safety may be adversely affected.

Starting & Driving

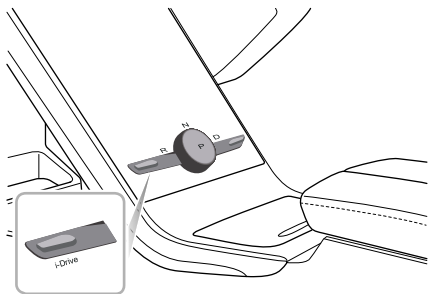

The driver can manually select five driving modes by operating the i-Drive switch on the electronic shifter in the infotainment display: WINTER Mode, ECO Mode, NORMAL Mode, SPORT Mode, SPORT+ Mode.

The information centre will display: WINTER, ECO, NORMAL, SPORT, SPORT+.

Toggle the i-Drive switch forward or backward to switch between the driving modes.

In each of the driving modes, the control system uses different control strategies for output control. It reasonably distributes the torque to the four wheels in accordance with the driver's intention, vehicle status and actual road conditions to improve the off-road drive capability, mobility, driving stability and safety of the car.

- **WINTER Mode**

WINTER Mode employs an AUTO mode for the all-wheel drive system. It is used for driving under special road conditions.

When the all-wheel drive system confirms that it needs the 4WD mode, it will reasonably distribute the torque to the four wheels without the driver's intervention.

- **ECO Mode**

ECO Mode also employs the AUTO mode for the all-wheel drive system. It optimises energy consumption. This will provide the best results regarding the range of the vehicle.

When the all-wheel drive system confirms that it needs the 4WD mode, it will reasonably distribute the torque to the four wheels without the driver's intervention.

Starting & Driving

- **NORMAL Mode**

NORMAL Mode also employs the AUTO mode for the all-wheel drive system. It combines economy and performance to meet the driving requirements of most drivers.

When the all-wheel drive system confirms that it needs the 4WD mode, it will reasonably distribute the torque to the four wheels without the driver's intervention.

- **SPORT Mode**

SPORT Mode also employs the AUTO mode for the all-wheel drive system. It concentrates on providing more power to enhance the performance.

When the all-wheel drive system confirms that it needs the 4WD mode, it will reasonably distribute the torque to the four wheels without the driver's intervention.

- **SPORT+ Mode**

SPORT+ Mode employs a 4WD mode for the all-wheel drive system. It achieves a highly perceptive power experience.

We recommend you use this mode under tough road conditions such as unpaved roads, bumpy roads, steep roads, sandy roads and slippery roads.

Every time the vehicle power system is cycled, and the system is then set to READY mode, the driving mode defaults to NORMAL mode.

In different driving modes, the power delivery, steering and air conditioning system varies. Please refer to the table below.

Driving Mode	Power Mode	Steering Mode	A/C Mode	Brake Mode
WINTER	ECO	Normal	ECO	Normal
ECO	ECO	Normal	ECO	Normal
NORMAL	NORMAL	Normal	Normal	Normal
SPORT	SPORT	Dynamic	SPORT	SPORT
SPORT+	SPORT	Dynamic	SPORT	SPORT

Note: Whilst WINTER or ECO mode is selected, the A/C will operate in a low energy consumption state to

Starting & Driving

provide an increase in vehicle power. To set the A/C, please refer to the infotainment display.

Note:

Ambient lighting can be linked with the driving mode. It will switch between different colours in different driving modes. When the ambient lighting is in the CUSTOM state, it will not be affected by the driving mode. To set the ambient lighting, please refer to the infotainment display.

All-Wheel Drive System Indicator Lamp



When the all-wheel drive mode is used, the indicator lamp illuminates green, and the information centre display shows “4WD System On”.

When the all-wheel drive system indicator lamp remains yellow, it indicates the system has detected a fault, and the information centre display shows “4WD System Fault”. Please seek an MG Authorised Repairer immediately.

In the 4WD mode, when the vehicle speed exceeds 130 km/h, the 4WD mode is deactivated, the indicator goes

off, and the vehicle reverts to 2WD mode; if the vehicle speed then drops to below 120 km/h again, the 4WD mode resumes.

Energy Regeneration (REGEN)



Deceleration effected by energy regeneration is NOT a substitute for braking safely. The driver must ALWAYS be prepared to make braking manoeuvres to maintain safe driving.

When the vehicle is in a braking, over-run or coasting state, the energy regeneration function is activated, and the motor converts part of the kinetic energy of the vehicle into electric energy, which is then stored in the high voltage battery.

Energy cannot be regenerated or is limited under some conditions, such as:

- N gear is selected (During driving do not coast in N gear) ;
- During torque intervention (SCS or traction control operation) ;
- High voltage battery is fully charged;
- High voltage battery temperature is too high or too low.

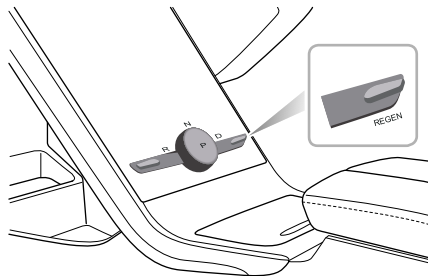

The driver can manually select three energy regeneration levels by operating the REGEN switch on the electronic shifter in the infotainment display.

Toggle the REGEN switch forward or backward to switch between three energy regeneration levels.

The energy regeneration system (REGEN) has three levels:

Heavy

Heavy Level: Maximum energy is regenerated, the vehicle exhibits shorter coasting distances and a strong sensation of over-run drag or motor braking. The information centre displays ③ .

Moderate

Moderate Level: Moderate energy regenerated. The information centre displays ② .

Light

Light Level: Minimum energy is regenerated, the vehicle exhibits longer coasting distances and no significant sensation of over-run drag or motor braking. The information centre displays ① .

Every time the vehicle power system is cycled, and the system is then set to READY mode, the energy regeneration level defaults to the Moderate Level. The information centre displays ② .

Protection Mode





When parking the vehicle, please ensure the vehicle is parked safely and that all traffic by-laws are observed.

Motor Overheating Protection of Electric Drive Transmission

The electric drive transmission may become very hot in a high-temperature environment with frequent starting, frequent rapid acceleration and deceleration, long-term continuous steep climbing, and overload of the electric drive transmission. In order to prevent damage to the motor, the system will perform an overheating protection function.

When the system detects the system coolant overheat, the warning message “EDU Coolant Overheating” displays.

When the system detects overheating in the electric drive transmission motor, the warning indicator  illuminates, and the warning message “Motor Overheating” displays simultaneously. After a few seconds, the warning message

will disappear but the warning indicator  will remain on.

In this case, park your vehicle safely or keeping a low load, continue to drive your vehicle at a constant speed to cool the motor. Only when the motor temperature has decreased, the warning indicator is off, and the warning message disappears, can the vehicle be driven normally.

If the electric drive transmission has cooled down for a long time (about 20 minutes) and the warning indicator has not disappeared, please park the vehicle safely and seek an MG Authorised Repairer immediately, otherwise it may seriously damage the electric drive transmission.

IMPORTANT

When the motor of the electric drive transmission is under overheating protection, in order to avoid damage to the motor, the power of the vehicle will be limited (the information centre will display “Power Limited, Limiting Speed”, and the warning indicator  will illuminate). After decelerating, the warnings will disappear when the motor temperature returns to normal.

Motor Fault of Electric Drive Transmission

If a fault or failure is detected in the motor or the power electronic box of the electric drive transmission, the warning indicator  illuminates, and the warning message “Motor Fault” displays simultaneously. Please seek an MG Authorised Repairer immediately.

Electric Drive Transmission Failure

In some cases, when a fault or severe failure is detected in the electric drive transmission, the warning indicator  illuminates yellow.

In some cases, the electric drive transmission will enter Limp Mode and will only function at certain speeds. Please drive carefully or seek an MG Authorised Repairer immediately.

Electric Drive Transmission Severe Functional Malfunction

In some cases, when a severe functional malfunction is detected in the electric drive transmission, the warning indicator  illuminates red, and the warning message “System Fault” displays simultaneously. After a few

seconds, the warning message disappears but the warning indicator  will remain on. To protect the electric drive transmission, the power system will isolate the power transmission, and the vehicle will not be drivable. Please seek an MG Authorised Repairer immediately.

In some cases, when a fault or severe failure is detected in the gear shift system, the information centre will display “EP”. For safety reasons, if the vehicle speed is below a preset speed, the power system will isolate the power transmission, and the vehicle will not be drivable. Please seek an MG Authorised Repairer immediately.

Brake System

Foot Brake

For added safety, the hydraulic braking system operates through dual circuits. If one circuit should fail, the other will continue to function, but greater pedal pressure will be needed, brake pedal travel will increase, and longer stopping distances will be experienced. In the event of a brake failure where only one circuit is operational, the car should be brought to a halt as soon as traffic conditions safely allow. **DO NOT** continue driving - seek an MG Authorised Repairer.

Wet Conditions

Driving through water or heavy rain may adversely affect braking efficiency. In this case, keep a safe distance from other vehicles and intermittently apply the brake pedal to keep the brake disc surface dry.

Electronic Hydraulic Brake Application System (EHBS)

The vehicle is equipped with an electronic hydraulic brake application system; always be aware of the following during operation:

- The EHBS system functions with the vehicle power system in READY mode only. Never allow the vehicle to freewheel with the power system turned off.
- If the power system should switch off or fail for any reason while driving, bring the car to a halt as quickly as traffic conditions safely allow, and depress the brake pedal with greater force. **DO NOT** continue driving - seek an MG Authorised Repairer immediately.
- If the EHBS system performance degrades due to a low battery or other reasons, you need to apply more force than usual to the brake pedal to stop the vehicle.
- If the EHBS system fails, the instrument pack message centre will illuminate the yellow warning lamp (⚠). At this point, the hydraulic booster compensation system starts to provide power assistance. While the power assist performance is relatively low, please slow down to a stop as soon as safety permits and contact an MG Authorised Repairer as soon as possible.

Braking Response Mode

EHBS provides 2 different braking response modes:

- Standard: provides a normal brake boost and brake pedal feel.
- Sport: provides an extra brake boost and a more sensitive brake pedal feeling.

The user is able to select the response mode via the drive mode selection function - refer to "Electric Drive Transmission" in the "Starting and Driving" section.

Note: *If the driving mode is switched whilst driving, the braking response may not change immediately. After the vehicle comes to a halt and the brake pedal released the mode will switch automatically.*

Hydraulic Booster Compensation System (HBC)

The vehicle is equipped with an hydraulic booster compensation system. If the EHBS system fails, the HBC system begins to provide power assistance. If any one of the HBC or EHBS systems fails while the other is capable of providing power assistance normally, the instrument pack message centre will illuminate the yellow lamp (ⓘ). At

this point, the power assist performance is relatively low. Please slow down to a stop as soon as safety permits and contact an MG Authorised Repairer as soon as possible.

If both the HBC and EHBS systems fail, the instrument pack message centre will illuminate the red lamp (ⓘ). In such a case, please stop the vehicle as soon as safety permits and contact an MG Authorised Repairer as soon as possible.

Note: *When the yellow lamp (ⓘ) in the instrument pack message centre illuminates and the HBC system begins to provide a braking assist, a buzzing noise may be heard when pressing the brake pedal. This is normal system operation in these conditions.*

Cooperative Regenerative Braking System (CRBS)

The vehicle is equipped with a cooperative regenerative braking system. This converts the kinetic energy of the vehicle into electric energy while braking and stores the energy in the HV battery, so as to prolong the driving range.

Note: *When the cooperative regenerative braking energy function is triggered, the driver may hear a small motor operational noise and feel a slight*

vibration on the brake pedal at low road speeds. This is a normal sensation when the system is triggered.

Electronic Brake Force Distribution (EBD)

The vehicle is equipped with EBD, which, in order to maintain braking efficiency, distributes braking forces between front and rear wheels, under all load conditions.

EBD integrates a monitoring system. The monitoring system is linked to the brake system malfunction indicator lamp on the instrument pack. Refer to "Warning Lights and Indicators" in the "Instruments and Controls" section.

If the indicator lamp illuminates while driving, or remains illuminated after the START/STOP Switch is turned on (ON/READY position), it indicates there is a failure with the braking system, and EBD may be inoperative. In such a case, stop the car as soon as safety permits and seek an MG Authorised Repairer immediately. DO NOT drive the car with the brake system malfunction indicator lamp illuminated.

Electronic Brake Assistance (EBA)

The vehicle is equipped with Electronic Brake Assistance (EBA). When the brake pedal is applied for emergency braking, the EBA system will help the driver increase the braking force acted on each wheel to reach the working point of ABS, thereby shortening the braking distance.

Hill Hold Control (HHC)



HHC has limitations when subject to adverse conditions such as wet or icy surfaces and steep slopes. The driver must always maintain control of the vehicle and attention should not be reduced just because HHC is enabled.



HHC is not a substitute for parking brake application when carrying out a hill start. DO NOT exit the vehicle with only HHC applied. It may lead to a serious accident when HHC releases.

Starting & Driving



The car may roll if 'pull-away' is not achieved immediately after releasing the brake pedal. Always ensure the brake pedal is pressed or electronic parking brake is applied until the car starts to move.



Firm application of the brake pedal when stopping is required by HHC to generate sufficient brake pressure to maintain a hill hold.

Hill Hold Control is a comfort function. It works on inclines when the car detects it has come to a 'stand still status'. It assists the driver by 'holding' the vehicle during hill starts.

The following conditions must be fulfilled to activate HHC:

- The driver's door is closed and the driver seat belt is fastened.
- The vehicle is stopped on a slope in excess of 4%.
- SCS is active and fault free.
- EPB is released and fault free.
- In D or R gear.
- Power system is READY/RUNNING.

- Sufficient brake pedal application force has been applied. As long as D or R is selected and the brake pedal is released, the vehicle will maintain pressure in the braking system for 1 ~ 2 seconds. After this, the Hill Hold will release.

If the driver releases the brake pedal on a hill, HHC will maintain brake pressure for 1 ~ 2 seconds. After this period the vehicle may roll backwards.

Note: When the HHC system is operating to keep the vehicle still, even if the driver releases the brake pedal, the pedal will not return to its initial position. It will remain in the pressed position. When the brake is released, the brake pedal will return to its initial position.

Note: HHC is available in both forward and backward directions when pulling away on uphill slopes.

Auto Hold



When Auto Hold is being used to stabilise the vehicle, shutdown the power system, releasing the seat belt or pressing the auto hold switch, the electronic parking brake is applied. It cannot be guaranteed that the vehicle will be stabilised in all cases. For example, when the rear wheels are on a slippery road surface, or the vehicle incline is too great (larger than 20%). Please make sure that the vehicle is safely stabilised prior to exiting.



DO NOT take any extra risks when driving due to the fact that the vehicle is fitted with additional convenience functions. The driver should pay full attention and observe the surroundings even if the vehicle is equipped with an auto hold system.



The auto hold function cannot guarantee the stability of the vehicle when starting off or braking on hills especially on slippery or icy surfaces.



DO NOT exit the vehicle when the power system is operating and the auto hold is active.



Auto hold cannot guarantee the electronic parking brake operation in all cases where the power system is turned off. Please ensure the electronic parking brake is applied and the vehicle is stabilised prior to exiting the vehicle.



The auto hold function should be switched off during the use of automatic car washes. The electronic parking brake may suddenly apply and cause vehicle damage.

With the power system active, if the vehicle is required to stop frequently for a length of time (such as traffic lights, traffic queues or stop/start), the auto hold system assists in stabilising the vehicle, enabling you to remove your foot from the brake pedal when the vehicle is stationary and the Auto Hold is active.

Auto hold has 3 main states:

- l Off: Function in Off state.

Starting & Driving

- 2 Standby: Function in Standby state; the function is activated but the vehicle is not parked, and the indicator light of the auto hold switch is on. Once the vehicle has stopped, and all other conditions are met, the system will automatically select Park.
- 3 Parking: Function in Parked state. In this state the green lamp (P) in the instrument pack illuminates.

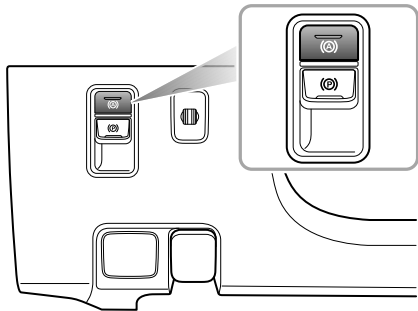

With the driver's seat belt fastened, the door closed and the power system operating, press the auto hold switch

to switch the auto hold function from Off to the Standby state.

With the brake pedal firmly pressed and the vehicle completely stopped, the auto hold function will switch from the Standby state to the Parking state.

When the auto hold is in the Parking state, engaging D or R and depressing the accelerator pedal will automatically release the auto hold function.

In some circumstances such as releasing the seat belt, switching off the power system or remaining static for a length of time, it will result in the vehicle exiting the auto hold Parking state. At this time the electronic parking brake will remain applied and will require the driver to release it using the switch.

Note: When the auto hold is in the parking state, even if the driver releases the brake pedal, the pedal will not return to its initial position. It will remain in the pressed position. When the auto hold automatically releases or when it is exiting the parking state and enabling the EPB, the brake pedal will return to its initial position.

Note: When the brake pedal is pressed, operating the switch to turn the auto hold off will **NOT** apply the parking brake.

Note: It is recommended to turn off the auto hold function when reversing into the garage.

Hill Descent Control System (HDC)



The HDC system is just an auxiliary function, which cannot overcome physical limitations to ensure that the vehicle drives down a slope at low speed in some cases (such as wet or icy surfaces or steep slopes).



Even when the HDC system is in use, the driver **MUST** pay close attention to the driving state of the vehicle, and take active control when necessary. Because in certain cases, HDC may remove itself from the operating state temporarily.



Under some driving conditions on downhill surfaces (e.g. driving down a slope at high speed, slope less than 10%), HDC is inoperative, so the driver **MUST** control the speed by depressing the brake pedal to maintain safe driving.

The HDC system is an auxiliary function specially designed for driving on acute downhill gradients and surfaces. The HDC system reduces the speed by applying a brake

Starting & Driving

force, thus assisting the driver to drive on acute downhill gradients and slippery surfaces at low speeds. Therefore, please do not use this function when driving on ordinary roads.

When the HDC is working, the brake system may generate strong vibrations or noise. This is normal during the operation of HDC.

Note: During the operation of the hill descent control (HDC) system, do not turn the shift knob to the N position. Such an operation may deactivate the HDC function.

HDC On/Off

When the START/STOP Switch is placed in the ON/READY position, the HDC system is off by default. The HDC system can be turned on or off by touching the button "HDC". The operation interface is in the entertainment display.

Normally, the HDC system has four states as follows:

- 1 Standby: Turn on the HDC switch to start the HDC system and enter into a standby state. The HDC indicator in the instrument pack illuminates green.

- 2 Operating: in Standby mode, when the vehicle drives down an acute slope or on a slippery downhill gradient, and the driver does not depress the brake and accelerator pedal, if the vehicle speed is low, the HDC system will automatically enter into the operating state. Meanwhile, the HDC indicator in the instrument pack flashes green, which may be accompanied by the working noise of the brake system, and the vehicle drives down the steep slope smoothly.
- 3 Temporary Deactivation: pressing the accelerator pedal or brake pedal to a certain extent in Operating mode will temporarily suspend the HDC from the operating state.
- 4 Off: touch the HDC switch again to turn off the HDC system.

Note: The HDC system works when the vehicle is driving forward or backward.

Note: When the vehicle steers at a fast speed on a hill with a certain gradient, the HDC system may switch from Standby mode to Operating mode.

Note: *With the HDC system in operation, the brake system will automatically pressurize and hold. When depressing the brake pedal at this time, you will experience a certain pressure feedback, which is normal during the operation of HDC system.*

HDC ON/Malfunction Indicator Lamp

Refer to "Warning Lights and Indicators" in the "Instruments and Controls" section.

Anti-lock Brake System (ABS)



ABS cannot overcome the physical limitations of stopping the car in too short a distance, running at too high a speed, or in danger of aquaplaning, i.e. where a layer of water prevents adequate contact between the tyres and the road surface.

The purpose of the anti-lock brake system (ABS) is to prevent the wheels from locking while braking, thereby enabling the driver to retain steering control of the car.

The fact that a car is fitted with ABS must never tempt the driver into taking risks that could affect his/her safety or that of other road users. In all cases, it remains the driver's responsibility to drive within normal safety margins, having due consideration for prevailing weather and traffic conditions.

Under normal braking conditions, ABS will not be activated. However, once the braking force exceeds the available adhesion between the tyres and the road surface, thereby causing the wheels to lock, ABS will automatically

Starting & Driving

come into operation. This will be recognisable by a rapid pulsation felt through the brake pedal.

Braking in an Emergency



DO NOT pump the brake pedal at any time; this will interrupt the operation of ABS and may increase the braking distance.

If an emergency situation occurs, the driver should apply full braking effort even when the road surface is slippery. ABS will ensure that the wheels do not lock and that the car is brought to a halt in the shortest possible distance for the prevailing road surface conditions.

Note: On soft surfaces such as powdery snow, sand or gravel, the braking distance produced by the ABS system may be greater than that for a non-ABS system, even though improved steering would be experienced. This is because the natural action of locked wheels on soft surfaces is to build up a wedge of material in front of the tyre contact patch. This effect assists the car in stopping.

No matter how hard you brake, you are still able to continue steering the vehicle as normal.

IMPORTANT

ABS can not reliably make up for the driver's mis-operation or lack of experience.

ABS Malfunction Indicator Lamp

Refer to "Warning Lights and Indicators" in the "Instruments and Controls" section.

Note: The normal (non-ABS) braking system remains fully operational and is not affected by partial or full loss of the ABS. However, the braking distances may increase.

Emergency Braking Hazard Warning Lights Control System (HAZ)

If the vehicle is travelling at high speed and the driver makes an emergency braking manoeuvre, the system will automatically flash the brake lamps to warn the following drivers, thereby effectively reducing the risk of rear-end collision accidents.

Note: *If the hazard warning lights are being operated manually, this suspends the HAZ function.*

When the emergency braking manoeuvre is exited (no severe deceleration detected) then the function will be switched off after a few seconds.

Multi-Collision Brake System (MCB)

The MCB function will automatically apply the brakes to reduce the vehicle speed and improve the vehicle stability after a collision. It is designed to reduce the risk of a secondary collision caused by the uncontrolled movement of the vehicle after a collision.

The multi-collision brake system will be activated when the following conditions are all met at the same time:

- A vehicle collision where seat belts or airbags are deployed;
- The vehicle speed is less than 60 km/h;
- The steering wheel has not been turned in excess of 180°;
- SCS is fault free.

After a collision or the MCB function is triggered, if the driver strongly presses the accelerator pedal, The system will not brake automatically.

Note: *The MCB function cannot decelerate the vehicle in all cases of collision, because the collision process may cause some parts to malfunction or fail and affect the normal operation of the function.*

Electronic Parking Brake (EPB)



In the event of an EPB malfunction where EPB release is not possible, please consult an MG Authorised Repairer in order to carry out an emergency manual release of the parking brake.

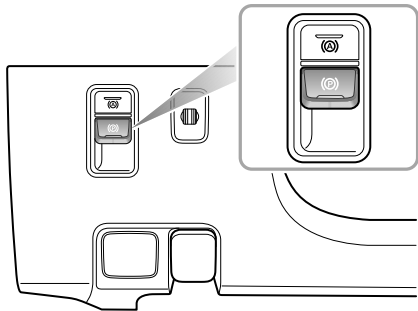

Applying the EPB

When the vehicle is parked safely, selecting P on the gear shift control knob will automatically apply the EPB. If automatic application of the EPB fails, it is necessary to manually apply the parking brake using the EPB switch

- Pull the EPB switch upward until the indicator in the EPB switch illuminates.
- If the indicator lamp in the EPB switch and the indicator lamp (P) in the instrument pack illuminate, it indicates that the EPB is applied.
- If the EPB MIL (P) in the instrument pack stays on, it indicates that the EPB has a fault. Please contact an MG Authorised Repairer immediately.

Note: *An audible motor noise may be heard when applying or releasing the EPB.*

IMPORTANT

- DO NOT leave the vehicle before the indicator in EPB switch illuminates and the gear indicator displays P, the vehicle may not be safely parked due to EPB failure and slip.
- In the event of a flat battery or power failure, it is not possible to apply or release the EPB. If 'jump leads' are being used to temporarily supply power, please see 'Emergency Starting' in the Emergency Information.

Releasing the EPB

If the vehicle power system is READY, press the brake pedal and use the shift control system to switch from P to N, D or R, the EPB will automatically release.

If automatic release of the EPB fails, it is necessary to manually release the EPB as follows or apply the start assist function of the EPB to release the EPB.

- Place the START/STOP Switch in the ON/READY position, press the brake pedal, and press the EPB switch;

- The indicator in the EPB switch and the indicator lamp (P) in the instrument pack are extinguished, the EPB is released.

Start Assist

The EPB can predict the driver's intention and automatically release the EPB.

If the driver's seat belt is fastened, the power system is READY, D or R gear is selected and the accelerator pedal is pressed in order to pull away. The EPB will automatically release.

Emergency Braking Function



Inappropriate use of the EPB can lead to accidents and injuries. DO NOT apply the EPB for vehicle braking during driving, unless in emergency.



During emergency braking using the EPB, DO NOT switch off the vehicle power system, this could result in serious injury.

Starting & Driving

In the event of normal brake failure, emergency braking using the EPB can be initiated by pulling and holding the EPB switch upward.

- Pulling and holding the EPB switch upward can realize emergency braking. During emergency braking using EPB, an audible warning will sound.
- To cancel the emergency braking process, release the EPB switch.

Stability Control System (SCS) and Traction Control System (TCS)

Stability Control System (SCS)

SCS is designed to assist the driver to control the driving direction. The SCS automatically enters Standby mode after the power system is started.

When SCS detects that the vehicle is not moving in the intended direction, it will intervene by applying brake force to selected wheels or through the power management system to prevent sliding and assist in bringing the car back to the right direction.

Traction Control System (TCS)

The purpose of TCS is to aid traction and driving stability, thereby helping the driver to maintain control of the car. TCS monitors the driving speed of each wheel individually. If spin is detected on one driving wheel, the system automatically brakes that wheel, transferring torque to the opposite, non-spinning wheel. If driving wheels are spinning, the system will reduce the output torque of the

power system in order to regulate wheel rotation until traction is regained.

Switching On/Off

SCS and TCS are automatically switched on when the START/STOP Switch is placed in the ON/READY position. They can be switched off by using the switch  located within the infotainment system display.

When SCS and TCS are switched off, Stability Control/Traction Control System OFF Warning Lamps in the message centre of the instrument pack will illuminate. Refer to "Warning Lights and Indicators" in the "Instruments and Controls" section.

Note: *Disabling SCS and TCS will not affect the operation of ABS. Always disable SCS and TCS when driving with snow chains fitted.*

Stability Control/Traction Control Warning Lamps

Refer to "Warning Lights and Indicators" in the "Instruments and Controls" section.

Driver Attention Warning System



Even if the vehicle is equipped with driver attention warning system, the driver should always ensure that his/her physical conditions are suitable for driving, and never drive the vehicle under fatigue condition.



The driver attention warning system cannot always accurately recognize the driver's fatigue level. It calculates the driver's fatigue level based on the driver's operation state, rather than monitoring the driver's actual physical characteristics such as distraction. It is also unable to give an emergency warning to the driver who has just fallen into fatigue.

The driver attention warning system calculates the driver's fatigue level by comparing information such as vehicle speed and steering wheel angle with basic data obtained based on mass data statistics. The system will constantly compare the calculated fatigue level with the current operation state of the driver. If the system recognizes that

the driver is already in a fatigued state, a warning will be issued.

When the vehicle speed is between 60-180 km/h, the driver attention warning system will operate. When the driver performs the following operations, the system will stop monitoring the driver's fatigue level:

- 1 The driver removes the seat belt and opens the driver door;
- 2 The stop time exceeds 15 minutes;
- 3 Turn off the START/STOP Switch.

Driver Attention Warning System Settings

The operating interface of the driver attention warning system is located on the entertainment display. Enter the Vehicle Settings interface to find "MG Pilot" option and choose the switch "Driver Attention Warning System" for setting:

- 1 When the START/STOP Switch is in the ON/READY state, the function can be enabled by default. Touch the corresponding button on the entertainment display to turn the driver attention warning system On/Off.

- 2 Touch the corresponding button on the entertainment display to adjust the alert sensitivity. The sensitivity defaults to the state when the last START/STOP switch indicator illuminated green. (ON/READY state).

The driver attention warning system will not trigger in the following conditions even if it is enabled:

- Driving on a continuous curve;
- Driving on a poor quality road surface;
- Driving on congested roads or roads with lots of traffic lights.

Adaptive Cruise Control System



The adaptive cruise control system is designed as a comfort system enabling the driver to maintain a constant speed or distance from the car in front. It provides assistance to the driver, it DOES NOT replace any of the drivers responsibilities. When using the adaptive cruise control system, it is important that the driver maintains concentration at ALL times and is prepared to take action. Otherwise, accidents or personal injuries may occur.

The adaptive cruise control system can automatically switch between constant speed cruise and car following cruise depending on whether it can detect a vehicle directly ahead. Constant speed cruise controls the vehicle at a certain speed range. Car following cruise operates by setting the distance between the vehicle and the vehicles directly ahead.

When activated if the adaptive cruise control system detects a vehicle in the same lane directly ahead it may

accelerate or gently apply braking of the vehicle to maintain the set following distance.

Note: *The adaptive cruise control system is designed for highways and roads in good condition. It is recommended not to be used on urban and mountain roads.*

Note: *Whilst in an adaptive cruise control state the system may be required to apply the brakes, at this time the brake pedal may sink. DO NOT put your foot under or behind the brake pedal, this risks personal injury.*

Adaptive Cruise Control System Activation



After following the vehicle ahead to a stop, the driver must observe any local traffic laws and ensure that there are no obstacles or other traffic participants, such as pedestrians, directly in front of the vehicle before allowing it to pull away and begin to follow the vehicle ahead again.

Starting & Driving



Whilst using the car following cruise function it is strongly recommended that the driver does not touch the accelerator pedal. Any activation of the accelerator will not allow the system to automatically apply the brakes should this be necessary.



DO NOT exit the vehicle when the adaptive cruise control system car following cruise function has stopped the car, or is keeping the car stationary. Before exiting the car the shift control knob should be in the Park position and the power switch in the OFF position.



If the adaptive cruise control system has already stopped the vehicle, and the adaptive cruise control function is disabled, turned off or cancelled, the vehicle will no longer stay still, it may move forward or slip backward. When the vehicle is stopped and kept still by the adaptive cruise control system, be sure to be ready to apply the brakes manually.



When driving on a bend, the adaptive cruise control may actively reduce the vehicle speed to maintain vehicle stability and safety.

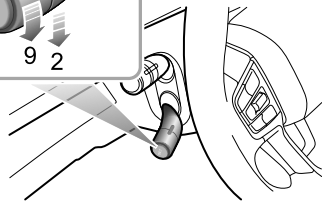
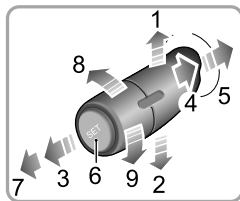

- 1 Speed Limit Increase/Accelerate
- 2 Speed Limit Decrease/Decelerate
- 3 Adaptive Cruise Cancel
- 4 Adaptive Cruise Standby
- 5 Adaptive Cruise Resume

Starting & Driving

- 6 Adaptive Cruise Set
- 7 Adaptive Cruise OFF
- 8 Increase Distance
- 9 Decrease Distance

The adaptive cruise control system is operated with a lever switch, which is located under the left side of the steering wheel.

- 1 With the vehicle START/STOP Switch in the ON position, if the adaptive cruise lever switch is in the 'OFF' position (7), then the adaptive cruise control system is switched OFF.
- 2 Move the adaptive cruise lever switch to the 'ON' position (4), the adaptive cruise control system is in the Standby mode.
- 3 The system will automatically detect the speed and position of the vehicle ahead, if your vehicle speed is above 5 km/h, after pressing the 'Set' button (6) at the end of the adaptive cruise stalk lever, the indicator on the instrument pack will turn green, and the adaptive cruise control system enters the Activated mode, its target speed is the actual speed at activation; if

your vehicle speed is less than 30 km/h, then the target speed of the system is set at 30 km/h. If the speed of the vehicle ahead is greater than the cruise target speed of your vehicle, your vehicle will maintain the target speed to conduct constant speed cruise. If the speed of the vehicle ahead is lower than the cruise target speed of your vehicle, it will enter the car-following cruise. An image of your car and the car ahead is displayed in the instrument pack message centre. In this mode the actual speed may be less than the set target speed. Whilst in the car following cruise mode, you can follow the vehicle ahead to a stop. If the parking time is less than a preset time period, your vehicle may automatically pull away to follow the vehicle ahead, or you need re-activate the adaptive cruise control system using the method displayed.

Note: *Manual deactivation of either the Traction Control System (TCS) or Stability Control System (SCS) will inhibit the operation of the adaptive cruise control system.*

Adaptive Cruise Target Speed Adjustment

When the adaptive cruise control system is activated:

Starting & Driving

- 1 Use the accelerator pedal to reach the desired speed, short press the 'Set' button (6) on the end of the adaptive cruise switch lever, release the control button and accelerator pedal. The vehicle will cruise at the desired speed.
- 2 Move the lever switch upward (1) and hold, the target speed will increase until the desired set speed appears in the instrument pack, then release the switch. When it is confirmed that there is no vehicle in front of your vehicle or the vehicle ahead exceeds the preselected following distance, the speed will be increased to the set speed.
- 3 Move the lever switch downward (2) and hold, the target speed will decrease until the desired set speed appears in the instrument pack, then release the switch, the vehicle speed will decrease to the set speed.
- 4 When using the lever to adjust the target speed, briefly operate the adaptive cruise lever switch upward (1) or downward (2) once, the target speed will change 5 km/h, press and hold the lever upward or downward and the speed will increase or decrease in 1 km/h

increments, release the lever when the desired speed reading is displayed.

Note: *If the vehicle ahead continually makes hard acceleration or deceleration manoeuvres the adaptive cruise control may not be able accurately maintain the required distance between vehicles. It is important that the driver always concentrates and pay attention to the current vehicle position and situation in case they need to make a braking or avoidance manoeuvre.*

Adaptive Cruise Target Following Distance Adjustment

When the adaptive cruise control system is activated, rotate the switch on the end of the lever upward (8) or downward (9) to adjust the following distance, you are able to toggle between 3 distance settings which are displayed in the message centre in the instrument pack.

Always select an appropriate following distance that is relative to the current speed of your vehicle and the vehicle you are following, the greater the speed, the further the distance. ALWAYS consider current traffic, road and weather conditions when making your selection.

Adaptive Cruise Pause/Standby

When the adaptive cruise control system is activated, move the lever switch to the 'Cancel' position (3), and the system will exit to the Standby mode.

Automatic Deactivation of Adaptive Cruise

In the following situations, the adaptive cruise control system may be automatically deactivated, this transfers full control of the vehicle to the driver.

- Move the lever switch to 'OFF' position (7).
- Press the brake pedal whilst the vehicle is in motion.
- Move the rotary gear knob to either R or N position.
- The driver unfastens his/her seat belt.
- Press and hold the accelerator pedal beyond a preset time period.
- Open any door, bonnet or tailgate.
- Pull the EPB switch up to apply the parking brake.
- Follow the vehicle ahead to a stop and the stop time exceeds a certain period of time.
- The camera or radar view is blocked, the surrounding environment triggers the preset safe exit mechanism of the sensors, or the system fails.

Note: *If following the vehicle ahead to a stop with the adaptive cruise control system enabled, if any of the following conditions occur whilst the vehicle is in a stopped state, the EPB will automatically be applied:*

- *The driver unfastens his/her seat belt.*
- *The driver door is opened.*
- *The stationary time exceeds the preset time period.*

Adaptive Cruise Override

If the driver has cause to use the accelerator pedal when the adaptive cruise control system is activated, the vehicle will remain in Cruise mode while the vehicle speed increases. When the accelerator pedal is released, the adaptive cruise control system will resume to operate at previously set cruise speed.

Adaptive Cruise Resume

If the adaptive cruise control system has reverted to, or been switched to, the Standby mode it can be reactivated by moving the lever switch to the 'Resume' position (5). The target cruise speed will automatically be set to the target speed before exiting the adaptive cruise control system.

Clear Speed Memory

If the lever switch is moved to the 'OFF' position (7) or the vehicle START/STOP Switch is switched to the OFF position, the system may clear the adaptive cruise control set speed in the memory.

Adaptive Cruise Control System Impairment and Ineffectiveness

- Encounters a vehicle or object which is stationary or traversing the lanes.
- Approaching the vehicle ahead too fast, and the system cannot apply sufficient braking force.
- The vehicle ahead is an oncoming vehicle, or makes an emergency braking manoeuvre.
- A vehicle suddenly cuts into the lane in front.
- Encounters a vehicle driving at a low speed.
- Encounters a vehicle with loaded items protruding from the body profile of the vehicle.
- Encounters a vehicle with a higher chassis (e.g., a truck).
- Encounters pedestrians, non-motor vehicles or animals.
- The vehicle is driving on an uneven road or a complex traffic road section.

- The vehicle makes a sharp turn.
- Enters and leaves a tunnel or drives in the tunnel.
- Drives in the shade of mottled trees.
- Excessive weight being carried in the boot space or cargo area causing the front of the car to point upwards.

Special Driving Environments

The adaptive cruise control system has its limitations. Listed below are some conditions that may be beyond the safe operating limits. The driver should maintain control of the vehicle and must remain alert at all times. They should pay special attention to the traffic conditions and surroundings, select the appropriate speed and be ready to take any required actions.

Starting & Driving

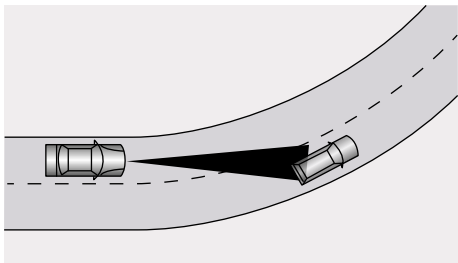
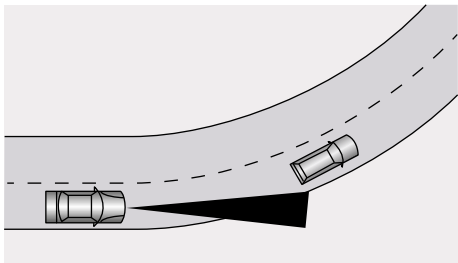

When turning at an intersection or following a vehicle into, or out of a curve, the adaptive cruise control system may be unable to detect the vehicle ahead, even if it is in the same lane, it is possible the system may detect a vehicle in another lane.

Note: *Do not use the adaptive cruise control system on entrance/exit ramps or sharp bends.*

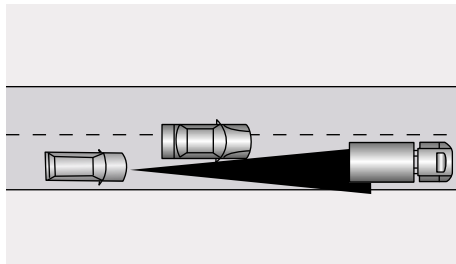

Starting & Driving

If the vehicle ahead changes lanes, but does not drive into the lane completely, the adaptive cruise control system may be unable to detect the vehicle.

If the vehicle ahead changes lanes, but does not exit the lane completely, the adaptive cruise control system may determine that the vehicle ahead has exited the lane and accelerate to any preset speed.

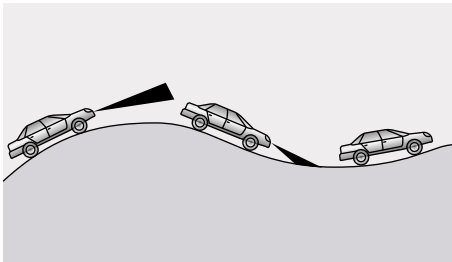

When driving on uneven roads that may include steep climbs or dips please **DO NOT** use the adaptive cruise control system.

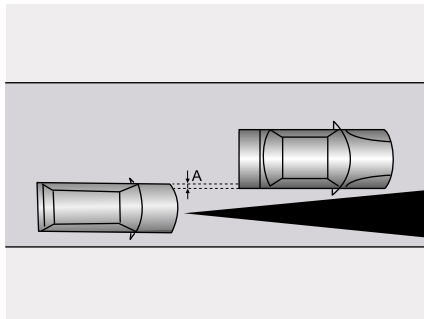

When driving behind a vehicle that is only partially overlapping your vehicle, 'A' in the graphic, the adaptive cruise control system may be unable to detect anything.

Note: Please DO NOT use the adaptive cruise control system in the following situations:

- **Driving in bad weather conditions.**
- **When the ambient light is insufficient, the light is too much, or the front lighting of the vehicle is poor.**
- **Driving on rough or poor road surfaces.**

Starting & Driving

- *Driving through roadworks or construction sites.*
- *Driving on low friction roads.*

Parking Aid System

Ultrasonic Sensor Parking Aid



The purpose of the parking aid is to assist the driver in judging distance in front and behind the vehicle when parking. The sensors may not be able to detect obstacles of certain type, e.g. narrow posts or small objects no more than a few inches wide, small objects close to the ground, objects above the tailgate and some objects with non-reflective surfaces.



Keep the sensors free from dirt, ice and snow. If deposits build up on the surface of the sensors, their performance may be impaired. When washing the car, avoid aiming high pressure water jets directly at the sensors from close range.

Ultrasonic Sensor

The ultrasonic sensors in the bumper monitor the area in front or behind the vehicle to search for obstacles. If

an obstacle is detected, the system calculates its distance from the front or rear of the car and communicates this information to the driver by an alarm sound.

Parking Aid Switch

The parking aid switch, a soft switch located in the entertainment display  allows the driver to manually turn the parking aid on or off.

When the vehicle is switched to R gear, the parking aid cannot be turned off.

Parking Aid in Operation

The parking aid is enabled automatically when the R gear is selected, it is switched off as soon as the R gear is disengaged. A short beep is given by the parking aid within 1 second after selecting R gear to indicate that the system is operating normally.

Note: *If a longer, higher pitched sound is emitted for 3 seconds when the R gear is selected, this indicates a fault in the system. In this case seek assistance from your MG Authorised Repairer.*

Starting & Driving

Front and rear parking aids can be turned on through the following methods:

- Select R gear;
- Manual selection via the parking aid switch.

Front and rear parking aids can be turned off through the following methods:

- Switch to P gear;
- When the vehicle speed exceeds 15km/h, the system will be automatically turned off;
- Manual selection via the parking aid switch.

With the parking aid enabled, when obstacles are detected, the system will emit sounds in different frequencies (there might be blind areas).

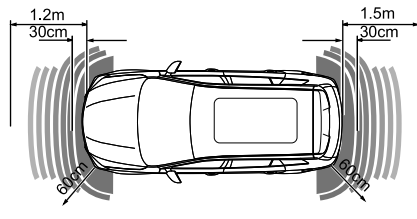

- If an obstacle is located within 1.5m range of the rear sensors or within 0.6m range of the corner sensors, the warning commences. As the car moves closer to the obstacle, the audible sounds are transmitted more rapidly.
- If an obstacle is located within 1.2m range of the front sensors or within 0.6m range of the corner sensors, the warning commences. As the car moves closer to the obstacle, the audible sounds are transmitted more rapidly.

- Once the obstacle is within 30cm range of the front and rear bumpers, the audible sounds will merge into a continuous warning.

360 Around View System *



The purpose of the 360 around view system is to assist the driver during parking. The cameras have a limited field of view and cannot detect obstructions outside the field of view.



Although the entertainment display can provide images around the vehicle, please still pay attention to the current actual road conditions for your driving safety.



Please ensure that the exterior rearview mirrors are unfolded when using the 360 around view system.

With the 360 around view system activated, the entertainment display will display the 360 degree panoramic image of the vehicle to facilitate the observation

of the surrounding environment in order to assist with safer driving. Buttons on the entertainment display can be touched to view the images from different angles around the vehicle.

The 360 around view system can be enabled using the following methods:

- Selecting Reverse gear.
- Operating the 360 button.
- Using the 'Setting' interface to select low speed switching of corner lights/indicators, this will automatically open the 360 around view system when the indicators are used at low speeds and exit when the indicators are cancelled.

In the 360 around view system display interface, select the settings icon to enable personal settings for system functions.

Note: *When the shift lever is placed in a forward gear position, the 360 around view system is inhibited at speeds above or equal to 30km/h.*

Rear Driving Assistance System

System Overview



The rear driving assistance function is only an aid, it is NOT a substitute for the attention of the driver. The driver must always remain in control, observe the surroundings and drive safely.



The effective recognition capabilities of the rear sensors can be limited by objects such as roadside buildings, guardrails, changes in pitch angle of the car due to heavy loading, road conditions such as bends or bumps or weather conditions such as snow and ice etc. Any of the above may trigger a false alarm.



The rear driving assistance system may not provide adequate warning of very fast approaching vehicles or operate correctly on tight curves of radius.



The rear driving assistance system will not operate correctly whilst towing a trailer or caravan.



The correct operation of the radar sensors will be compromised if they are misaligned due to accident damage. This may cause the system to automatically shutdown.



To ensure that the radar sensors work correctly, the rear bumper should be kept free of snow and ice and must not be covered.



Use of non recommended materials or paint on rear bumper repairs may have a detrimental effect on the operation of the rear sensors. Please only use recommended materials.

The rear driving assistance system includes blind spot detection (BSD), lane change assistance (LCA), rear cross traffic alert (RCTA) and door opening warning (DOW) functions.

Starting & Driving

The rear driving assistance modules are mounted at the rear of the vehicle on each side, they can assist in detecting vehicles behind or to the side of your vehicle, warning lamps to support this system are located within the LH and RH door mirror glasses and door switch packs, they will illuminate or flash to warn of an approaching object or car to assist you in manoeuvring the car safely.



Note: *The radar requires calibration on new vehicles or for vehicles where a rear detecting radar sensor has been replaced. The rear detection radar sensors possess an automatic calibration function to compensate for installation error within a certain range. When the vehicle is running, the radar will*

automatically enter the calibration state. During the calibration process, the system will provide limited functions, and the alarm may be inaccurate. Upon completion of the calibration, the system will resume all functions.

Switching the System Functions On/Off

The rear driving assistance system switch is a soft switch located in the entertainment display, Select ON/OFF to activate/deactivate the system.

Starting & Driving

System Functions

Note: *The detection area, collision time threshold value and vehicle speed provided in the system function description are just for your reference.*

Blind Spot Detection Function

When the vehicle is driving forward, the system will monitor the motor vehicles located in the blind zones of the left and right exterior mirrors. When the activation conditions are met, the warning lamps on the exterior rearview will remain on. Subsequent operation of the relevant indicator will cause the warning lamp to flash to remind the driver of an approaching vehicle.

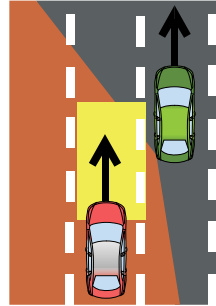

Blind spot detection function activation conditions include:

- 1 No faults are present in the system.
- 2 Blind spot detection function is enabled.
- 3 The vehicle speed is above 15km/h.
- 4 There are motor vehicles in the blind zone of the vehicle. The left and right areas, which are 1m ahead and 7m behind the rear of the vehicle, and 3.5m to the side of the vehicle are the system detection areas.

Starting & Driving

Note: *The warning lamps will not illuminate whilst you are overtaking another vehicle and your speed is greater than that of the vehicle you are passing, even though it is in the blind zone.*

Lane Change Assistance Function

When the vehicle is driving forward, the system will monitor the motor vehicles approaching rapidly in the adjacent lanes. When the indicators are activated, and the conditions for activating the lane change assistance function are met, the system will flash the respective warning lamp to warn the driver of an approaching vehicle. This aims to help avoid collisions when changing lanes.

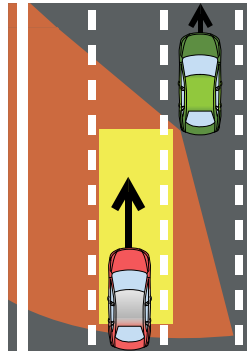

Starting & Driving

Lane change assistance function activation conditions include:

- 1 No faults are present in the system.
- 2 Lane change assistance function is enabled.
- 3 The vehicle speed is higher than 15km/h.
- 4 The speed of the approaching vehicle is higher than the speed of your vehicle.
- 5 The approaching vehicle enters the detection area of the lane change assistance, the monitored areas are 7m - 70m behind your vehicle and 3.5m to the side of your vehicle.
- 6 The approaching vehicle is likely to have a collision with your vehicle within 3.5 seconds.

Rear Cross Traffic Alert Function

When the vehicle is reversing, the system will monitor vehicles approaching from the left and right rear. When the conditions for activating the rear cross traffic alert function are met, the warning lamps on the corresponding side will illuminate, simultaneously a warning triangle icon for the corresponding side will be displayed in the entertainment display to alert the driver to the situation.

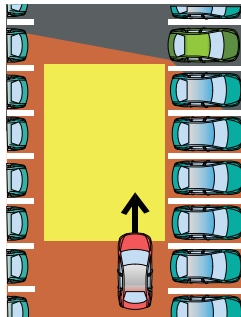

Rear cross traffic alert function activation conditions include:

- 1 No faults are present in the system.
- 2 Rear cross traffic alert function is enabled.
- 3 The vehicle is in R gear.
- 4 The vehicle speed is less than 10km/h.
- 5 The speed of the monitored vehicle is above 10km/h.
- 6 The motor vehicle drives across the system detection area. The areas monitored to the left and right of the vehicle are 7m behind the rear of the vehicle, and 30m from the side.
- 7 The approaching vehicle is likely to have a collision with your vehicle within 3 seconds.

Door Opening Warning

Whilst the vehicle is stationary, the door opening warning system monitors the surrounding area for approaching vehicles, motorcycles and bicycles. If the approaching object meets the conditions programmed into the system the corresponding warning lamps will illuminate, subsequently, if the door is opened, the corresponding warning lamps will flash accompanied with an alarm sound to warn the occupant of the approaching object and assist in avoiding any collisions .

Starting & Driving

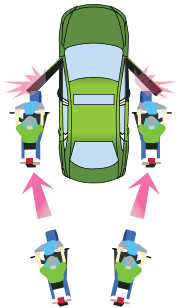

Door opening warning function activation conditions include:

- 1 No faults are present in the system.
- 2 Door opening warning function is enabled.
- 3 The vehicle is in the ACC/ON/READY state.
- 4 The vehicle is stationary.
- 5 The speed of the monitored vehicle is above 10km/h.
- 6 The monitored vehicle drives across the system detection area. The detection areas are the rearward of the door mirrors and 2.5 metres from each side of the vehicle.
- 7 The approaching vehicle is likely to have a collision with your vehicle within 3 seconds.

Tyre Pressure Monitoring System (TPMS)



TPMS can not replace routine maintenance and checks of tyre condition and pressures.



Using equipment that transmits on frequencies similar to that of the TPMS may interfere with the operation of the Tyre Pressure Monitoring System, this may illuminate a warning or register a temporary fault.

Note: *TPMS only warns of low tyre pressures, it does not re-inflate the tyre.*

TPMS uses pressure sensors built into tyre valves to continuously monitor pressure and transmit data to the ECU inside the vehicle using RF signals. If it deduces that the pressure of that tyre has fallen below the predefined limit of the system, the warning light in the instrument pack will illuminate (always yellow). For more information, please refer to 'Instrument Pack' in 'Instruments and Controls' section. TPMS can remind you

of low tyre pressure, but it can not replace normal tyre maintenance. For tyre maintenance, please refer to 'Tyres' in 'Maintenance' chapter.



If the TPMS malfunction indicator lamp illuminates, and the warning message "XX Tyre Pressure Low" is displayed, it is advised that you please stop the car as soon as possible, check the tyre pressure and inflate the tyre to correct pressure value. Driving with under-inflated tyres may overheat and cause tyre fault. Over or under-inflated tyres wear out more rapidly and also have a detrimental effect on the car's handling characteristics. Under-inflated tyres increase the rolling resistance of the car which, in turn, increases power consumption. Always check/adjust tyre pressures when they are cold.

Note: *After changing the tyre position or replacing a TPMS sensor and receiver, the vehicle needs to run at a speed of 40km/h for about 10 minutes to correctly indicate the tyre pressure value at the corresponding position.*

Driving Assist System

The driving assist system can detect the road and environmental information ahead of the vehicle by utilising a front view camera and a front detection radar under certain conditions. This information is used to relay warning messages or provide assistance to help the driver in controlling the vehicle in a safer and more reliable manner. The front view camera is located in the interior rearview mirror base cover, the front detection radar is located at the lower middle of the front bumper.

Note: DO NOT operate any infotainment switches whilst driving. If you wish to make any settings changes, please pull over when it is safe and legal to do so.

Description of Front View Camera

Calibration of front view camera

The front view camera will require re-calibration after any of the following operations:

- Removal and refitting of the front view camera.
- Replacement of the windscreen.

Note: The calibration of front view camera requires professional knowledge and tools. If calibration is required, please seek an MG Authorised Repairer.

Obstruction of the front view camera

On occasion the front view camera view may become obstructed by foreign objects or stains on the glass. In these cases a prompt message will appear in the information centre. Please wipe or clean immediately.

In the following situations, the detection performance of front view camera will be affected:

- Driving in poor weather conditions where visibility is reduced due to thick fog, heavy rain, snow, dust or sand storm etc.
- Affected by light, for example low light levels at night, poor auxiliary lighting, excessive backlighting in the view, light from oncoming vehicles, abrupt change of brightness with a quick bright/dark jump (tunnel entrance/exit), driving on surfaces with strong reflective

properties (road surface covered with water or snow), tunnels, inside a building etc.

- The front view camera view is partially or fully blocked by obstacles, e.g. dust, foreign objects, oil pollution, mud, snow, excessive water (rain), frost or water spray from the road on the windscreen.
- The windscreen viewing area is damaged.
- Not calibrated after removing/refitting the front view camera or the windscreen.
- The front view camera is not secured in place.

Description of Front Detection Radar

Calibration of front detection radar

Front detection radar re-calibration is required after any of the following:

- Front detection radar mis-alignment failure, for example the position of the front detection radar has changed.
- Remove/refit the front detection radar or radar bracket.
- Remove/refit the front anti-collision beam.
- The four-wheel alignment parameters have changed.

Note: *If the front detection radar is subject to strong vibration or slight impact, the mounting position of*

the front detection radar needs to be checked and re-calibrated as necessary.

Note: *The calibration of front detection radar requires professional knowledge and tools. If calibration is required, please seek an MG Authorised Repairer.*

Front radar performance will be effected in the following situations:

- When the front detection radar is covered by mud, snow, excessive water (rain) or water spray from the road.
- When the radar or surrounding areas are covered by objects such as labels or auxiliary lighting installation.
- When the front detection radar is subject to strong vibration or slight impact.
- Some targets may affect and weaken the detection capability of the front detection radar, such as road barriers, fences and tunnel entrances.
- When the front detection radar is affected by the environment, such as strong electromagnetic field interference or due to the target itself.

- Strong reflected radar signals (such as: in multi-storey car parks, tunnels, sprinkler spray systems or water jets etc). Experiencing any of these could cause the function of the front detection radar to be effected.

Note: *Any snow that gathers on the front radar may be removed using a soft brush, and any ice should be removed using a propriety deicing spray.*

Note: *Avoid any collision or contact with the front radar module, this may cause misalignment.*

Speed Assist System



The intelligent speed limit is an auxiliary function. It may display an incorrect speed limit value or no speed limit value in the instrument pack due to various factors. As a result, the vehicle speed is not restricted within the correct range. The driver still needs to observe the speed limit of the road traffic, and speeding is strictly prohibited.



The front view camera cannot recognise speed limit signs painted on the road surface. The driver MUST observe these speed limits and adjust the their speed accordingly.

The speed assist system settings are available via the infotainment system. Enter the Vehicle Setting interface to locate the speed assistance system option and switch on or off the overspeed alert function. When the adaptive cruise control system is OFF, you are able to choose from the intelligent speed limit function, manual speed limit function or switch off.



- 1 **Overspeed alert:** The vehicle detects a speed limit sign (as shown above) at the roadside with the front view camera. The speed limit sign identified will be displayed in the instrument pack. When the vehicle speed exceeds the speed limit by a preset amount, a visual warning in the instrument pack will flash.
- 2 **Intelligent speed limit:** The vehicle detects a speed limit sign (as shown above) at the roadside with the front view camera. The speed limit sign identified will be displayed in the instrument pack. The system will automatically intervene and maintain speed control to keep the vehicle speed within the permitted maximum speed limit. A visual warning will be utilised when over speed.
- 3 **Manual speed limit:** The driver sets the maximum speed using the adaptive cruise control lever. The system will actively intervene and keep the vehicle speed within the permitted maximum speed limit. A visual warning will be utilised when over speed. Please

refer to the section “Speed settings of manual speed assist”.

Speed assistance system setting

The operating interface for the speed assistance system is located in the infotainment display. Enter the vehicle setting interface to locate the speed assistance system option to find the setting interface for the speed assistance system:

- 1 Touch the corresponding button on the infotainment display to turn the overspeed alert function On/Off.
- 2 Touch the corresponding button on the infotainment display to select the speed assist mode: manual speed limit, intelligent speed limit.

Speed settings of manual speed limit:

After the manual speed limit function is enabled, the speed limit value can be set by using the adaptive cruise control lever as follows:

- 1 Moving the control lever up to adjust the speed limit. After the speed limit value is displayed in the instrument pack, press the SET button (3 in the figure below), the manual speed limit function will be

Starting & Driving

activated. When pressing the SET button, if the actual speed value is smaller than the setting, the speed limit value displayed in the instrument pack will be defined as the setting. If the actual speed value is larger than speed limit adjusted, the speed limit value displayed in the instrument pack will be defined as the current actual speed and rounded to the nearest value of 5km/h (62km/h will be defined as 65km/h). Moving the lever up or down once will increase or decrease the speed limit value by 5km/h. Holding the lever up or down will continuously change the speed limit value in units of 5km/h.

- 2 After the manual speed limit function is activated, the system will actively intervene and keep the vehicle speed within the target speed limit. If the current actual speed exceeds the target speed limit value set by the driver, the system will reduce the speed until it is below the target speed limit.
- 3 After the manual speed limit function is activated, the driver can press the SET button (3 in the figure below) on the adaptive cruise control lever to reinstate the system to standby state. Press the SET button again, the manual speed assist function will be resumed.

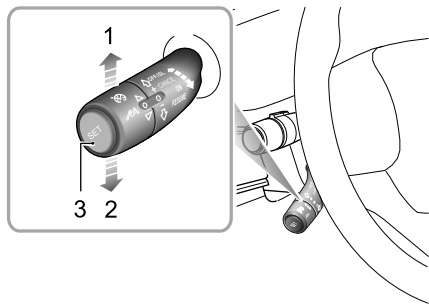

When the overspeed alert function or intelligent speed limit function is enabled, the speed limit value indication illuminates. When the vehicle passes the first speed limit sign identified, the speed limit indication displays the real-time speed limit value.

Note: When the vehicle needs to change lane, make a turn or turn around at an intersection and the driver uses an indicator in advance and slows down, the

Starting & Driving

original speed limit value on the instrument pack will be reset until a new speed limit sign is detected. If the conditions are not met, the original speed limit value will be maintained and not be reset. The driver MUST observe the speed limits and adjust their speed accordingly.



When the intelligent speed limit function is enabled, the system indicator lamp in the instrument pack illuminates yellow. When the function is activated by pressing the SET button on the adaptive cruise control lever, the system indicator lamp illuminates green. If the intelligent speed limit assist function detects a fault or failure, the indicator lamp will flash yellow then extinguish. Please try to restart this function. If this function cannot be turned on, please contact an MG Authorised Repairer.



When the manual speed limit function is enabled, the system indicator lamp in the instrument pack illuminates yellow. When the function is activated by pressing the SET button on the adaptive cruise control lever, the system indicator lamp illuminates green. If the

manual speed assist function detects a fault or failure, the indicator lamp will flash yellow then extinguish. Please try to restart this function. If this function cannot be turned on, please contact an MG Authorised Repairer.

NNN
km/h

When the manual speed limit function is enabled, the speed limit value indication illuminates. Move the adaptive cruise control lever up and down to adjust the target speed limit value. The “NNN” will show the adjusted speed limit value.

The driver can directly switch off, or temporarily suspend the intelligent speed limit function manual speed limit function by carrying out the following actions:

- 1 To temporarily exceed the speed limit (overtaking manoeuvre), press the accelerator pedal hard. The indicator lamp in the instrument pack illuminates green, and the speed limit value flashes.
- 2 Gently press the SET button on the end of the adaptive cruise control lever, the indicator lamp in the instrument pack will change to yellow. Press the SET button again to resume the functions.

Starting & Driving

- 3 Move the adaptive cruise control lever to the “ON” position to switch the speed assistance system off. Then the indicator lamp in the instrument pack will extinguish.

The overspeed alert function and intelligent speed limit function may be impaired in the following situations:

- 1 The detection performance of the front view camera is affected.
- 2 The vehicle is driven at a high speed.
- 3 The speed limit signs are obscured by trees along the road, ice/frost, snow, dust, etc.
- 4 The speed limit signs are incorrectly placed or damaged.
- 5 There are multiple speed limit signs above the lane or on the sides of the road. Currently, the front view camera can only recognise the speed limit signs for the lane in which the vehicle is being driven.
- 6 Non standard speed limit signs or signs that contain additional information.

- 7 The speed limit signs set up at a fork in the road, on a bend or on-ramp/off-ramp.
- 8 During manoeuvres such as lane-changing.

IMPORTANT
<ul style="list-style-type: none">• The camera may not correctly recognise speed limit signs during poor lighting conditions, bad weather, non-standardized or sheltered speed limit signs or the camera's own restrictions which include the recognition of similar signs (e.g., recognise a weight limit sign as a speed limit sign, or recognise a minimum speed sign as the maximum speed sign).• Some drastic or rapid steering operations made by the driver may be judged as changing lane or turning around at an intersection by the system. This will result in the identified speed limit signs being cleared.

Lane Assist System



The lane assist system is an auxiliary system that provides assistance to the driver. It does NOT remove the responsibility of safe driving from the driver. When choosing to use the lane assist system, the driver MUST always pay attention to the surroundings, hold the steering wheel and be prepared to make manoeuvres at any time. Failure to maintain overall control of the vehicle may result in an accident or personal injury.



The lane assist system does not always recognise the lane lines. Sometimes poor road surfaces, certain road structures or objects may be mistaken for lane lines. When such situations occur, the lane assist system must be immediately turned off.

The lane assist system switch is located in the infotainment display. Enter the corresponding interface for driving assistance to turn the system ON/OFF, and make mode selection.

Alert

The system uses the front view camera to detect the lane lines ahead of the vehicle. The system will be activated when the following detection conditions are met:

- The function is switched ON,
- Vehicle speed is above 60 km/h,
- Lane line markings are clear and the system recognises at least one lane line.

When a wheel is about to cross the lane line, or has already crossed the line, the system will provide warnings to prompt the driver to take action and maintain the vehicle position between the lane lines. The function will automatically exit when the vehicle speed drops below 55 km/h.

Emergency lane keeping

The system detects the following objects:

- Lane lines ahead of the vehicle,
- Curbs ahead of the vehicle,
- Oncoming vehicles in the adjacent lane,
- Overtaking vehicles in the adjacent lane.

Starting & Driving

The system will be activated when the following detection conditions are met:

- The function is switched ON,
- Vehicle speed is above 60 km/h,
- Lane line markings are clear and the system recognises at least one lane line.

When a wheel is about to cross the lane line or curb, has already crossed the line or curb, or the vehicle in the adjacent lane is nearing the vehicle and the vehicle is leaning to the middle lane line simultaneously, the system will provide assistance to the driver by keeping the vehicle in between the lane lines or curbs, or avoiding sharply by applying corrective steering intervention and simultaneously displaying a prompt. The function will automatically exit when the vehicle speed drops below 55 km/h.

In cases of several interventions within a certain period of time and in the absence of detecting any steering input by the driver during the interventions, the system will provide warnings.

IMPORTANT

- In cases where the number of lanes increase or lanes merge, the driver **MUST** take full control of the vehicle.
- In areas where there are complex traffic conditions such as intersections or road junctions with congestion, the driver **MUST** take full control of the vehicle.

The lane assist system will be impaired or ineffective in the following conditions:

- The hazard lamps are activated.
- The driver indicates in the direction of the lane line about to be crossed.
- The driver applies the accelerator rapidly, carries out an emergency manoeuvre or makes a hard brake pedal application.
- The system detects that the driver has not moved the steering wheel for a preset time period (in the mode of emergency lane keeping).
- During system intervention the steering wheel is operated (in the mode of emergency lane keeping).

- The lane line is too thin, damaged, or fuzzy.
- The vehicle is driven on the bend with a small curvature radius, the road is too narrow or too wide.
- The vehicle has just entered a road section with lane lines or is driven on a road section without lane lines.
- The vehicle changes lanes or sways laterally too fast.
- The vehicle is not in D.
- The vehicle speed is below 55 km/h, or too high.
- The anti-lock brake system (ABS) and the dynamic stability control system (SCS) are activated.
- Faults exist in the anti-lock brake system (ABS), dynamic stability control system (SCS), electric power steering system (EPS), etc.

It is recommended to turn off the lane assist system in the following situations:

- Driving in a sports style or manner.
- Driving in bad weather conditions.
- Driving on rough or poor road surfaces.
- Driving through roadworks or construction sites.

Traffic Jam Assist System



Traffic jam assist system is an auxiliary system that provides assistance to the driver. It does NOT remove the responsibility of safe driving from the driver. When choosing to use the traffic jam assist system, due to the limitations of system detection and control, the driver must always be careful and hold the steering wheel at all times. The driver needs to correct or take over the steering wheel control if necessary. Failure to maintain overall control of the vehicle may result in an accident or personal injury.

Starting & Driving

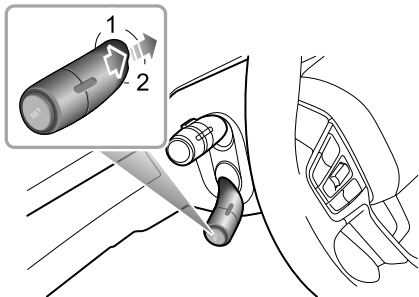

After turning on the adaptive cruise control system, operating the adaptive cruise control level to “RESUME” twice will switch the traffic jam assist system to standby or active state.

The traffic jam assist system works on the basis of the adaptive cruise control system. The system will operate when the following conditions are met:

- The adaptive cruise control system is activated.

- The system detects lane lines on both sides of the vehicle.
- The vehicle is in D.

If the lane lines ahead on both sides are clear, the system can assist the vehicle in driving within the lane lines. When driving at low speed, if there is a vehicle ahead and the lane lines ahead on both sides aren't clear, the system also can assist the vehicle in following the track of the vehicle ahead.

In the absence of a steering input from the driver for a certain period of time, the system will provide warnings.

Note: *The driver should adjust the vehicle speed and the following distance according to the road visibility, weather and road conditions. The traffic jam assist system does not respond to pedestrians, animals, stationary vehicles and vehicles that drive across the lane or oncoming vehicles in the same lane. If the traffic jam assist system cannot reduce the vehicle speed timely and effectively, the driver MUST apply the brakes. In congested conditions, should another vehicle cut into the lane being used by the vehicle under traffic jam assist system control, the system may not detect the vehicle in adequate time to make*

a braking manoeuvre. In this case the brakes should be applied by the driver.

The traffic jam assist system will be impaired or ineffective in the following conditions:

- The hazard lamps are activated.
- The driver indicates in the direction of the lane line about to be crossed.
- The driver applies the accelerator rapidly, carries out an emergency manoeuvre or makes a hard brake pedal application.
- The system detects that the driver has not moved the steering wheel for a preset time period.
- During system intervention, the steering wheel is being manipulated by the driver.
- The lane line is too thin, damaged, or fuzzy.
- The vehicle is driven on the bend with a small curvature radius, the road is too narrow or too wide.
- The vehicle has just entered a road section with lane lines or is driven on a road section without lane lines.
- The vehicle is not in D.
- The vehicle changes lanes or sways laterally too fast.

- The anti-lock brake system (ABS) and the dynamic stability control system (SCS) are activated.
- Faults exist in the anti-lock brake system (ABS), dynamic stability control system (SCS), electric power steering system (EPS), etc.

It is recommended to turn off the traffic jam assist system in the following situations:

- Driving in a sports style or manner.
- Driving in bad weather conditions.
- Driving on rough or poor road surfaces.
- Driving through roadworks or construction sites.
- Driving on steep, winding or slippery roads (such as snow and ice roads, wet roads and roads with water).
- Driving on grass tracks or unpaved roads.

IMPORTANT

- In cases where the number of lanes increase or lanes merge the driver **MUST** take full control of the vehicle.
- In areas where there are complex traffic conditions such as intersections or road junctions with congestion, the driver **MUST** take full control.
- The driver **MUST** be aware of the surroundings and be able to assume full control of the vehicle when using the traffic jam assist system to track the car in front should the need arise.

Forward Collision System



*The driver remains responsible for the safety of the entire driving process, even if the vehicle is equipped with a forward collision system. The driver **MUST** pay full attention and drive carefully. As with all the driver assist systems, the forward collision system cannot prevent accidents or avoid collisions in all situations. The driver **MUST** always remain in control to avoid accidents or emergency situations.*



*Emergency braking whilst under the control of the forward collision system may cause injuries to the passengers. Therefore, drive carefully and all passengers **MUST** wear seat belts at all times.*



Ensure the forward collision system or vehicle power system is switched off when being towed. If the forward collision system is enabled when the vehicle is being towed, adverse effects may affect the safety of your vehicle, the towing vehicle and the people around.



To avoid the occurrence of accidents, never specially test the functions of the forward collision system.

The forward collision system switch is located in the infotainment display. Enter the corresponding interface for driving assistance to turn the system ON/OFF, and make mode selection.

Alert

When the system detects that there is a risk of collision between the vehicle and the vehicle in front in the same lane, warnings will be provided to prompt the driver to slow down in time and keep a relatively safe distance from the vehicle ahead.

Emergency braking

When the system detects that there is a risk of collision between the vehicle and the vehicle or the mobile pedestrian directly in front of the vehicle, the brake system will automatically intervene to decelerate the vehicle, so as to avoid collision accidents or mitigate damage from collision accidents. If the vehicle is braked and stopped under the system control, it will remain stationary for a short time. Full control of the vehicle will then be returned to the driver.

The system will only slow down the vehicle automatically if the following conditions are met:

- The dynamic stability control system (SCS) and traction control system (TCS) are fault-free and ON.
- The vehicle is in D or N.
- The airbags are not deployed.

Note: When the vehicle is braked under system control, the brake pedal will automatically sink. DO NOT place your foot under or behind the brake pedal to prevent pinching.

Note: In some cases, the driver may not have anticipated any braking intervention and does

Starting & Driving

not want to apply the brakes whilst the forward collision system is braking heavily, the driver can temporarily cancel this operation by heavily pressing the accelerator pedal after ensuring that it is safe to do so.

The operation of the forward collision system may be impaired or ineffective in the following situations:

- The vehicle ahead approaches head-on, crosses the intersection or jumps the queue rapidly in a short distance.
- The vehicle ahead does not follow the rules of driving and parking (such as drives on the lane lines).
- The vehicle ahead is not in the same lane as your vehicle or the vehicle ahead is partially obscured.
- The vehicle ahead is an abnormal vehicle (modified or abnormal shape).
- The vehicle ahead is a vehicle with higher chassis.
- The vehicle ahead is large vehicle at close range (such as tractor, trailer, towing vehicle, mud truck, sanitation truck, sprinkler truck etc.).
- The vehicle ahead is unusual transportation (such as a horse, cart, carriages etc.).
- The system detects the side of a vehicle.
- The contour of the vehicle ahead is unclear (such as water being sprayed by the wheels of the front and surrounding vehicles).
- The vehicle ahead does not have or has obscured tail lamps when driving at night or in a tunnel.
- The tail lamps of the vehicle ahead are all LED strip lights or other homemade coloured lamps.
- The street lights are inconsistent or flickering when driving at night.
- The pedestrian is not directly in front of the vehicle, or the pedestrian is not fully visible.
- The pedestrian is not standing upright, or it is a child under a certain height.
- In front of the vehicle are a crowd of pedestrians, the pedestrian is over-shadowed or in the dark.
- There are animals in front of the vehicle.
- Objects such as special-shaped ground obstacles (e.g. roadblocks, isolation piles, isolation strips, large stones,

Starting & Driving

other scattered objects etc.) are detected in front of the vehicle.

- Objects such as signs, guardrails, bridges, buildings or other are detected in front of the vehicle.
- The vehicle is being driven on hillside road, upper and lower bridge section or tight bend.
- The vehicle is in R.
- The vehicle is in the state of braking or rapid acceleration.

Starting & Driving

Load Carrying



DO NOT exceed the gross vehicle weight or the permitted front and rear axle loads when loading. Failure may result in vehicle damage or serious injury.

Loadspace Loading



Ensure that the rear seat backrests are securely latched in the upright position when loads are carried in the load space behind the seats.



If the boot lid (or tailgate) can not be closed due to the type of cargo loaded, be sure to close all windows during driving, select the face distribution mode of the air condition, and set the blower to maximum speed, so as to decrease any fumes entering the vehicle.

When luggage is carried in the load space, always ensure heavy items are placed as low and as far forward as possible,

so as to avoid cargo shift in the event of an accident or sudden stop.

Drive carefully and avoid emergency braking or hard acceleration when loaded with large or heavy articles.

Note: The loading weight of the front loadspace MUST not exceed 25kg, or it may cause damage.

Driving with the boot lid (tailgate) open is very dangerous. If the load being carried requires the boot lid (or tailgate) to be open, the cargo and the boot lid (or tailgate) must be secured, and corresponding measures must be taken to prevent road dust and debris from entering the vehicle.

IMPORTANT

Relevant traffic regulations must be observed when loading. If the cargo extrudes the loadspace, appropriate warning measures must be taken to warn other road users.

Internal Loading



DO NOT carry unsecured equipment, tools or luggage that could move, causing personal injury in the event of an accident, emergency braking or hard acceleration.



DO NOT create an obstruction that prevents the driver or passenger from maintaining the correct sitting posture or obscures their vision.

Folding the rear seats can increase the luggage space, refer to “Rear Seats” described in the “Seats and Restraints” section.

When cargo is loaded in the vehicle, place it at a position as low as possible and ensure that it is tightly secured, so as to avoid personal injury caused by cargo movement when a traffic accident or emergency braking occurs. If the cargo has to be placed on a seat, no one is allowed to sit on that seat.

General Towing Safety

Your vehicle can tow a trailer if you carefully observe load limits, use approved equipment, and follow the towing guidelines. Always check load limits before towing.

Towing loads in excess of the maximum towing weight can seriously affect vehicle handling and performance, and could damage your vehicles motor/s and drive-train.

Note: Exceeding any load limits advised by MG Motor Europe is dangerous. Consult the recommended load limits and loading prior to any journey.

Check the loading of your vehicle and trailer carefully before starting to drive.

The trailer hitch load should never exceed the limit advised by MG Motor Europe.

Note: Excessive towing loads reduce front tyre traction and steering control, too little trailer nose load can make the trailer unstable and cause it to sway.

Tow bars: Only genuine MG approved tow bars should be fitted to your vehicle. Only use the attachment method specified by the vehicle manufacturer for securing the

Starting & Driving

towing hitch. Contact your authorised MG dealer for more information.

Safety chains: Safety chains must be used as a precautionary measure should the trailer become unintentionally unhitched. Make sure the safety chain is securely attached to both the trailer and the vehicle prior to departure.

Altitude: Your engine delivers less power at higher altitude. If you tow a trailer in a mountainous area you should reduce the combined vehicle and trailer weight by 10% for every 1000 m of elevation.

Gradients: Where possible, when towing, you should plan your journey to avoid steep gradients. The advised brake towing mass that is stated assumes a maximum gradient capability of 12%. Where possible it is recommended you drive on gradients less than 12%. Follow the trailer associations recommendations for suitable roads.

Running in period: Avoid towing a trailer during your vehicles first 1000 km.

Stop/Start function: On vehicles fitted with a Stop/Start function, manually switch the Automated Stop/Start function OFF when towing. The trailer weight can affect your vehicle's braking efficiency if Automated Stop/Start is activated on a hill while towing a trailer.

Emergency Information

234 Hazard Warning Devices

235 eCall - SOS Emergency Assistance

237 Emergency Starting

240 Vehicle Recovery

245 Tyre Repair

252 Fuse Replacement

260 Bulb Replacement

Emergency Information

Hazard Warning Devices

Warning Triangle

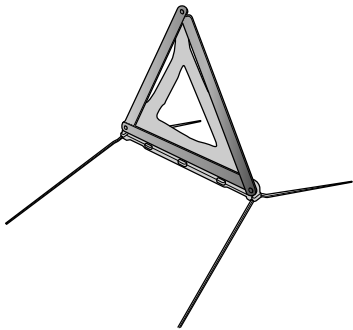

possible, and press the hazard warning lamp button, to warn other road users of your position.

The warning triangle supplied with your vehicle is stowed in the loadspace.

If you have to stop your vehicle on the road in an emergency, you must place a warning triangle approximately 50 — 150 metres behind the vehicle, if

eCall - SOS Emergency Assistance

In an accident, your vehicle's eCall – SOS Emergency Assistance can either be triggered manually or in severe cases automatically upon detection by the vehicle's sensors. The eCall service is a public service of general interest and is accessible free of charge. The emergency call centre will establish verbal communication with the vehicle occupants in order to understand the extent of the emergency and the level of assistance required. If verbal communication is not achievable, an attempt will be made to send the following vehicle information message to the emergency call centre. The appropriate emergency services will be deployed to the vehicle's current location if known.

- Current time, location and direction of travel
- Vehicle type
- Vehicle identification number (VIN)
- Whether the call was automatically or manually initiated
- Vehicle category
- Number of passengers

This system will ensure that your personal data is securely protected. It is designed to ensure that it is not traceable and other external systems are not available. When the

eCall triggers, the system will only transmit the data information to the relevant public safety answering points designated by the respective public authorities of the country on which territory they are located, which will receive and process your emergency call request. The system will retain data locally within 13 hours of triggering.

You have the right to access the data information stored in this system, and to request the rectification, erasure or blocking of data information that does not meet the requirements of the regulations. When you think your personal data is infringed, you have the right to complain to the competent data protection authority.

For manual activation, press and release the SOS button in the overhead console for 1 second to activate an emergency services call. A single beep will be heard when the eCall is triggered and a message will be displayed on the vehicle's message centre and entertainment player. The entertainment player will be muted whilst the emergency services call is active. Manually triggered emergency services calls may be cancelled by pressing and releasing the SOS button again within 5 seconds of the initial press. Two beeps will be heard confirming that the emergency

Emergency Information

services call has been cancelled and the messages will be removed.

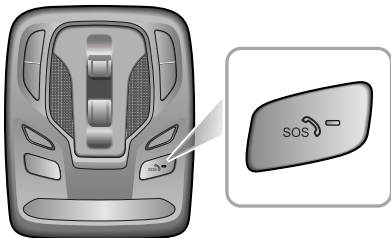

The emergency services call (eCall) system will perform a self-test when the START/STOP Switch is turned ON. During a Self-Test the emergency services call (eCall) LED status indicator on the SOS button will flash quickly until completion. The LED status indicator will be illuminated solid if no system faults are present. The LED status

indicator will be extinguished or flash slowly if a fault is detected. Faults detected during the self-test will be displayed on the vehicle's message centre.

Note: *The operation of eCall - SOS Emergency Assistance relies on cellular coverage and may be affected by signal outages or low signal strength.*

Note: *The automatic emergency services call (eCall) function may be disabled by the local MG Authorised Repairer upon request. It is strongly recommended that the eCall function is not disabled. MG Motor accepts no responsibility for any consequences caused by disabling this function.*

Emergency Information

Emergency Starting



NEVER attempt to power the vehicle by pushing or towing.



Make sure that both batteries are of the same rated voltage (12 volts), and that the booster cables are approved for use with 12 volt car batteries.



Ensure sparks and naked flames are kept well away from the front compartment.



Ensure that each booster cable connection is securely made. There must be no risk of the clips accidentally slipping from the battery terminals (as a result of any movement or vibration, for example), this could cause sparking, which could lead to a fire or personal injury.

If the 12 volt battery loses power, or becomes low on power, booster cables can be used to connect the battery of a donor vehicle or external battery to start the vehicle.

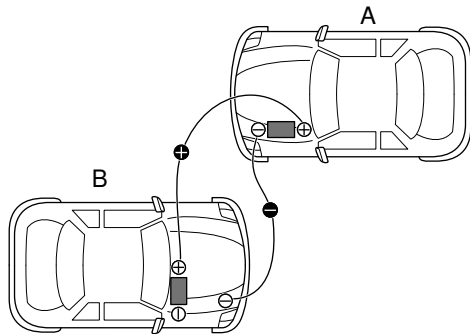

Depending on the configuration of the vehicle, the location of the battery is different. The battery for two-wheel drive vehicle is located at the rear right side of the front compartment, while the battery for four-wheel

Emergency Information

drive vehicle is located at the front left side of the front compartment.

Ensure the START/STOP Switch is turned off and switch off ALL electrical equipment of BOTH vehicles, then follow the instructions below:

- 1 Connect the RED booster cable between the positive (+) terminals of both batteries. Connect the BLACK booster cable from the negative (-) terminal of the donor battery (A) to a good earth point (the fixing point of headlamp in front compartment or other unpainted surface, for example), as far away from the battery as possible and well away from brake lines on the disabled vehicle (B).

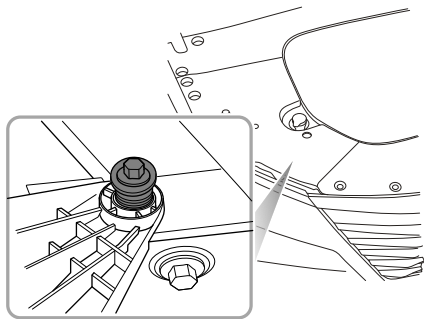

- 2 Start the donor vehicle and allow it to run for a few minutes.
- 3 Now switch the vehicle power system of the vehicle with the discharged battery to READY. If the disabled vehicle will not switch to READY it may need to be repaired. Please contact an MG Authorised Repairer.
- 4 After both the vehicles have normally started/powerd, leave the vehicles connected in this

Emergency Information

state for more than 2 minutes before switching off the donor vehicle and disconnecting the booster cables.

- 5 Disconnecting the booster cables must be an exact reversal of the procedure used to connect them, i.e. disconnect the **BLACK** cable from the earth point on the disabled vehicle **FIRST**.

IMPORTANT
DO NOT switch on any electrical appliance in the disabled vehicle until the booster cables have been disconnected.

Note: *It is recommended to ensure that the disabled vehicle remains powered or runs for more than 1 hour after it is started, in order to recover the battery power.*

Emergency Information

Vehicle Recovery

Towing for Recovery



When pushing or towing the vehicle from a dangerous situation or onto the transporter, the speed must remain below 5km/h and be completed within 3 minutes.



When pushing or towing the vehicle onto the transporter, the driver's side seat belt should be inserted into the lock and maintained in the inserted state in order to release the EPB.

Towing Hook



DO NOT use a tow rope that is twisted - or the towing hook may be unscrewed.

Emergency Information

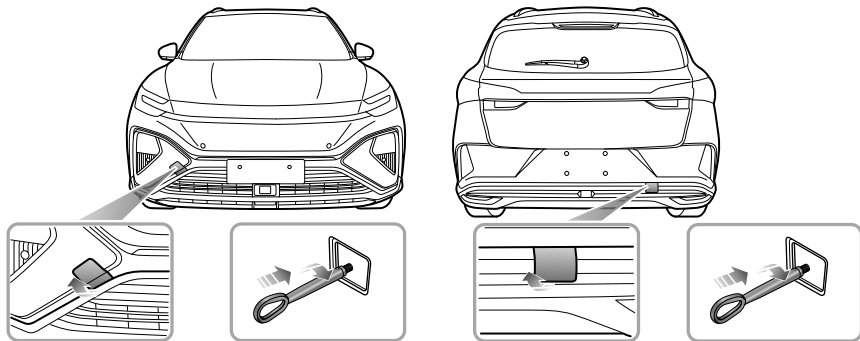

Your car is equipped with 2 towing eyes (located at the front and the rear of the vehicle), which are used for fitting the towing hook in the tool kit. The tool kit is placed beneath the loadspace floor.

To fit the towing hook, remove the small cover set into the bumper, then screw the towing hook via the small hole into the threaded hole in the bumper beam (see illustration). Ensure the towing hook is fully tightened!

Note: *The towing eye cover may be secured to the bumper by a plastic cord.*

Emergency Information

Both towing points are intended for use by qualified recovery specialists to assist in the recovery of your car when a breakdown or accident occur. They are not designed for towing other vehicles, and must NEVER be used to tow a trailer or caravan. The vehicle can be towed using a tow rope but a towing bar is recommended.

Emergency Information

Towing for Recovery



When towing, DO NOT suddenly accelerate or brake suddenly, this can cause accidents.



DO NOT tow the vehicle with any of the 4 wheels in contact with the road surface, this will avoid electric drive transmission damage.

Suspended Towing



When using suspended towing, be careful not to let the high voltage battery pack touch the ground.

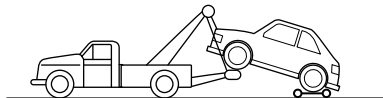
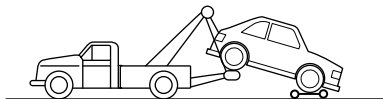

Suspended towing is the best method for recovering a vehicle that needs to be towed. The driven wheels **MUST** be suspended above the ground, this is to avoid any damage to the electric drive transmission and possible inadvertent powering of the vehicle. Ensure the EPB is released, the hazard lamps are ON and no passengers are in the vehicle.

Emergency Information

Transporter or Trailer with Rope

If your car is to be transported on the back of a trailer or transporter, it must be secured as illustrated:

- 3 Fit the lashing straps (3) around the wheels and secure to the trailer. Tighten the straps until the car is securely held.

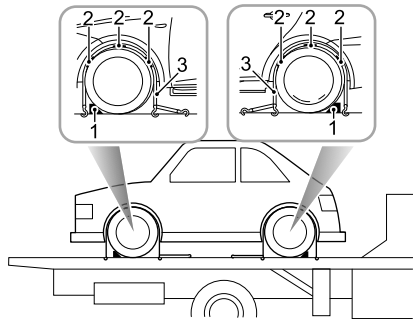

- 1 Apply the parking brake and place the electric drive transmission in park.
- 2 Fit wheel chocks (1) as shown, then position the anti slip rubber blocks (2) around the circumference of the tyre.

Emergency Information

Tyre Repair

Tool Identification

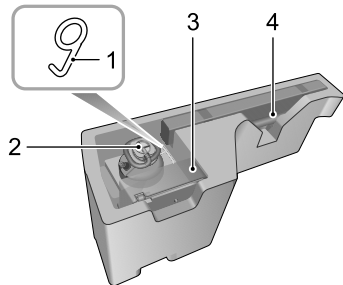

- 1 Wheel Bolt Cap Removal Tool
- 2 Repair Fluid
- 3 Electric Air Pump
- 4 Towing Hook

Tyre Repair

- 1 Remove the label at the bottom of the repair fluid reservoir and attach it to the steering wheel to remind the driver not to exceed 80 km/h.

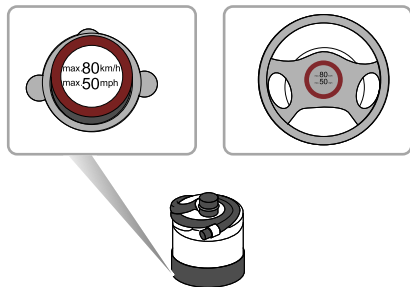

- 2 Connect the air hose of the electric air pump to the repair fluid reservoir, fit the tyre sealant bottle (upright) into the slot on the compressor. Remove the valve dust cap of the flat tyre, and connect the filler hose from the tyre sealant bottle to the tyre valve. Ensure that the power switch of the electric

Emergency Information

air compressor is switched off (i.e., press “O”), then insert the plug from the compressor into the centre console power socket, and turn the START/STOP Switch to ON/READY.



Note: To avoid battery discharge, it is recommended to keep the vehicle in P and READY mode.

- 3 Switch on the switch of the electric compressor (i.e., press “-”), to start pumping sealant into the tyre. The tyre sealant bottle will become empty after approximately 30 seconds. The tyre should reach the specified pressure within 5 or 10 minutes.

Note: The pressure gauge may briefly reach 6 bar (87 psi), then the pressure begins to drop to normal.

- 4 When the required pressure is reached, switch off the power switch of the electric compressor (i.e., press “O”).

Note: If the required pressure cannot be reached within 10 minutes, please disconnect the compressor, drive the vehicle 10 metres approx forward or backward to allow the sealant to spread within the tyre. If the required pressure can still not be reached, the tyre is severely damaged and you should seek assistance from an MG Authorised Repairer.

Note: Consecutive operation of the electric air compressor for more than 10 minutes may result in damage to the compressor.

Emergency Information

Note: Under no circumstances should you continue your journey with a deflated tyre. Driving a vehicle with a deflated tyre is extremely dangerous.

- Remove the tyre sealant bottle from the slot in the compressor, disconnect the hose from the tyre valve, remove the compressor plug from the centre console power socket, return the tyre repair kit to its stowage tray.
- After successfully adding sealant to the tyre, drive immediately for a short time (around one minute). This will allow the sealant to distribute evenly inside the tyre. Continue driving and do not exceed 80 km/h. After a further 10 minutes, find a safe place to stop and recheck the tyre pressure.

Please take different measures based on the tyre pressure measured:

- If the tyre pressure has dropped to less than 0.8 bar (11.6 psi), do not continue driving, seek assistance instead.
- If the tyre pressure is between 0.8 bar (11.6 psi) and specified pressure, connect the hose of the

electric air pump to the tyre valve, and connect the plug of the electric air pump to the power socket, then switch on the electric air pump to inflate the tyre until it reaches the specified pressure. Repeat the operations of step 6 after driving a maximum distance of 5km.



- If the tyre pressure has not dropped, you may continue driving, but the vehicle speed must not exceed 80 km/h, and the driving mileage must not exceed 200 km.

Emergency Information

Note: *DO NOT* remove foreign objects (eg. screws, nails) from the tyre. The tyre repair system must only be used when the foreign object is in the tread pattern (A). *DO NOT* attempt a repair when the damage is in the sidewall of the tyre (B).

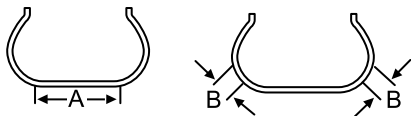

Changing a Wheel *

If you need to change the wheel during the journey, choose a safe place to stop away from the main road if possible. Always ask your passengers to get out of the car and wait in a safe area away from other traffic.

Switch on hazard warning lamps. If available, position a warning triangle about 50 to 150 metres behind your vehicle to warn approaching traffic.

Before changing a wheel, ensure the front wheels are in the straight ahead position. Apply the parking brake and place the gear shift lever of transmission in N position.

Observe the following precautions:

- Ensure the jack is positioned on firm, level ground.
- If the vehicle must be parked on the hill, place blocks in front of and behind the other 3 wheels to prevent the vehicle moving.

Positioning the Jack



NEVER work beneath the car with the jack as the only means of support. The jack is designed for wheel changing only!

Emergency Information



NEVER jack the car using any jacking points other than the jacking points. Serious damage to the car could result.

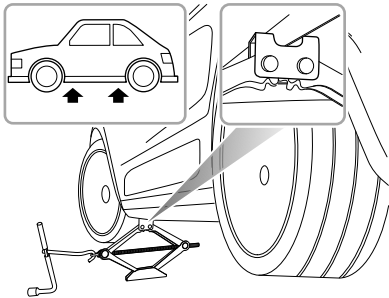

Avoid accidental contact with any underbody parts, especially hot exhaust system and high voltage components.

Position the jack on firm level ground under the jacking point nearest the wheel to be removed. Note that the

domed head of the jack must fit into the corresponding recess in the sill plate (There is a triangle indicator in the area shown by the arrowhead).

Turning the jack screw by hand, adjust the jack until the jack head fits snugly onto the sill in the correct area. Ensure that the base of the jack is in full contact with the level ground.

Fitting the Spare Wheel



Regularly check the spare wheel tyre pressure, it may not be used for long periods of time. After fitment, at the first opportunity check and adjust the tyre pressure.



The wheel bolts must be tightened to the specified torque after changing a wheel (135 ~ 165Nm).

- 1 Before raising the car, use the special tool supplied with the vehicle to remove each wheel bolt cap. Use the wheel bolt spanner to slacken each bolt half a turn anti-clockwise.
- 2 Turn the handle in a clockwise direction until the tyre is clear of the ground.

Emergency Information

Note: For your safety, please put the spare tyre under the vehicle body flanging area near the jack. Avoid the outer side of the wheel contacting the ground, and the rim surface may be scratched.

- 3 Remove the wheel bolts and place them in the tool tray to prevent them from being lost. Make sure the vehicle is steady and there is no risk of a slip or movement before removing wheel bolts.
- 4 Remove the road wheel.

Note: Replace the spare wheel with the removed wheel and place it under the vehicle body flanging area near the jack. Avoid the outer side of the wheel contacting the ground, and the rim surface may be scratched.

- 5 Fit the spare wheel and tighten the wheel bolts with wheel bolt spanner until the wheel is seated firmly against the hub.
- 6 Lower the car and remove the jack, then FULLY tighten the wheel bolts in a diagonal sequence.
- 7 Finally, return the tools to the toolbox, put the toolbox into the well of the boot floor, tighten the spare wheel

retaining nuts, and put the replaced wheel above the toolbox in the well in the load space floor (face down). Lower the boot floor, and put the boot storage box on the boot floor.

Note: DO NOT stand on the handle of the wheel bolt spanner or use extension tube on the handle of the spanner.

Note: When replacing the wheel, please fully tighten the bolts in the diagonal sequence twice.

Note: Consult your MG Authorised Repairer or tyre specialist for a replacement tyre as soon as possible.

Spacesaver Spare Wheel



Only one spacesaver spare wheel can be used at any one time, otherwise the operational performance and brake performance may be reduced, thereby leading to accident or injury to yourself and others.

Emergency Information



When driving on icy or slippery surfaces it is advised to fit the spacesaver wheel to the rear of the vehicle to maintain adequate stability. This may mean swapping a front wheel with a rear wheel.



Snow chains can not be used on the spacesaver spare wheel, this can cause damage to the car and snow chain.

When the spacesaver spare wheel is fitted, the vehicle speed should not exceed 80km/h. Please have the full sized tyre repaired or replaced and replace the spare wheel as soon as possible. This will extend the life span of the spare wheel for other emergencies.

Note: DO NOT use an automatic car wash when the spacesaver wheel is fitted, the guide rails of the car wash may conflict with the wheel/tyre and cause damage.

Emergency Information

Fuse Replacement

Fuse

Fuses are simple circuit breakers which protect the car's electrical equipment by preventing the electrical circuits from being overloaded. A blown fuse may be indicated when the item of electrical equipment it protects stops working.

If you suspect a fuse, it can be checked by removing it from the fuse box and looking for a break in the wire inside the fuse.

It is recommended to have spare fuses in the vehicle, which can be obtained from a local MG Authorised Repairer.

IMPORTANT

- NEVER attempt to repair a blown fuse. ALWAYS replace a fuse with one of the same rating. Failure to use the correctly rated fuse could result in a fire or electrical circuit damage due to overloading.
- If a replaced fuse fails immediately, please contact an MG Authorised Repairer as soon as possible.

Fuse Box

The vehicle is equipped with 2 fuse boxes:

- 1 Front compartment fuse box: is located in the front right of the front compartment. Remove the front right side panel to access the fuse box.
- 2 Passenger compartment fuse box: is behind the driver side lower trim panel. Remove the knee baffle to access the fuse box.

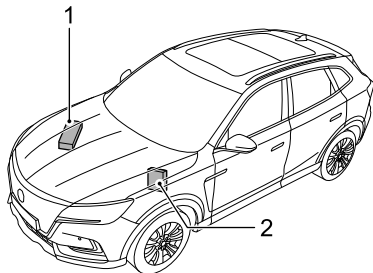

Emergency Information

Front compartment fuse box

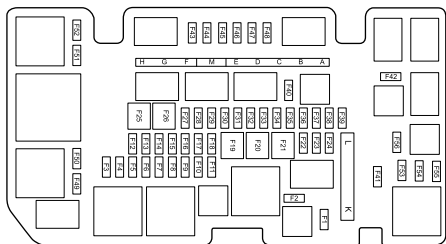

Check or Replace a Fuse

- 1 Turn off the Start/Stop Switch and all electrical appliances, and disconnect the negative battery cable.
- 2 Press the lock catch to open the upper cover of front compartment fuse box.
- 3 Check a suspect fuse by removing it from the fuse box and looking for a break in the wire inside the fuse.
- 4 If a fuse is blown, replace it with another fuse of the same type and same ampere value.

Fuse Specification

Code	Specs	Function
F1	120Ω	On-board Network Termination Resistor
F2	120Ω	On-board Network Termination Resistor
F3	20A	Body Control Module
F4	20A	Body Control Module
F5	20A	Body Control Module
F6	30A	Door Handle Retraction System
F7	5A	Vehicle Control Unit
F8	5A	Combined Charging Unit
F9	15A	Horn, Horn Relay
F10	10A	E-Call TBOX
F11	10A	High Voltage Battery Pack

Emergency Information

Code	Specs	Function
F12	5A	Active Grille Shutter
F13	5A	Rear Right Power Electronic Box
F14	5A	Ambient Light Control Module
F15	15A	Left Headlamp Assembly
F16	5A	Front Power Electronic Box
F17	10A	Front Bonnet Opening System
F18	5A	HD-360 Around View Module
F19	30A	Power Liftgate Control Module
F20	30A	Gear Shift Motor Controller
F21	30A	Power Liftgate Control Module

Code	Specs	Function
F22	15A	High Voltage Battery Pack Coolant Pump
F23	15A	Right Headlamp Assembly
F24	5A	High Voltage Battery Pack Heater
F25	30A	Passenger Window Lift, Rear Right Window Lift
F26	30A	Stability Control System (Valve)
F27	15A	Windscreen Washer System
F28	20A	Body Control Module
F29	20A	Body Control Module
F30	25A	Front Wiper System
F31	5A	Rear Left Power Electronic Box, High Voltage Battery Pack Pressure Alarm Switch

Emergency Information

Code	Specs	Function
F32	20A	Body Control Module
F33	15A	Front Compartment Fuses F45, F46
F34	25A	Main Relay, Front Compartment Fuses F49, F50
F35	5A	Charging Status Indicator
F36	5A	Electric Air Conditioning Compressor
F37	5A	Digital Audio Broadcast, Electric Vehicle Communication Controller
F38	15A	Rear Wiper System
F39-F42	-	-
F43	7.5A	Heated Exterior Rearview Mirror

Code	Specs	Function
F44	25A	Heated Rear Window
F45	10A	Air Quality Sensor, PM2.5 Sensor, Anion Generator, Hot Pump Controller, Light Adjustment Switch, Interior Mirror
F46	5A	Headlamp Leveling
F47	10A	Left Front Signal Lamp Assembly
F48	10A	Right Front Signal Lamp Assembly
F49	5A	Brake Lamp Switch, Cooling Fan
F50	20A	Power Electronic Box Coolant Pump
F51-F56	-	-

Emergency Information

Code	Specs	Function
FUSE A	80A	Electric Power Steering Module
FUSE B	-	-
FUSE C	40A	Stability Control System (Pump)
FUSE D	-	-
FUSE E	-	-
FUSE F	30A	Electrical Parking Brake Control Module
FUSE G	50A	Cooling Fan
FUSE H	50A	iBooster
FUSE M	150A	Combined Charging Unit
FUSE L	30A	Electronic Parking Brake Control Module
FUSE K	100A	Passenger Compartment Fuse Box

Passenger Compartment Fuse Box

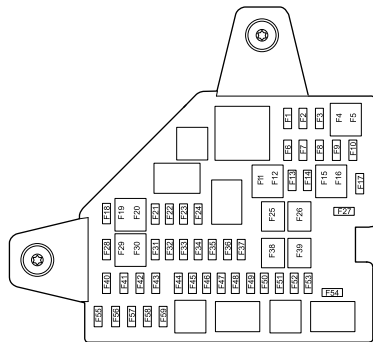

Check or Replace a Fuse

- 1 Turn off the Start/Stop Switch and all electrical appliances, and disconnect the negative battery cable.
- 2 Remove the driver side dashboard end cover plate and lower trim panel to access the fuse box.

Emergency Information

- 3 Check a suspect fuse by removing it from the fuse box and looking for a break in the wire inside the fuse.
- 4 If a fuse is blown, replace it with another fuse of the same type and same ampere value.

Fuse Specification

Code	Specs	Function
F1	15A	Front Console Power Socket
F2	5A	Phone Wireless Charger, Rear USB Charging Module
F3	-	-
F4	10A	Front Seats Vent
F5	5A	PDC Sensor
F6-F16	-	-
F17	120Ω	On-board Network Terminal Resistance

Code	Specs	Function
F18	5A	Body Control Module, Instrument Pack, Shifter Control Unit, Sensing Diagnostic Module (Airbag), Vehicle Control Unit
F19	7.5A	Front Central Display
F20	10A	AC Control Module
F21	25A	Front Passenger Electric Adjust Seat
F22	5A	Diagnostic Socket
F23	10A	Memory Seat Module
F24	5A	PEPS Control Module
F25	-	-
F26	30A	Driver Window Lift, Rear Left Window Lift

Emergency Information

Code	Specs	Function
F27	-	-
F28	5A	Backup Immobilizer Coil
F29	20A	Entertainment System
F30	5A	Instrument Pack
F31	5A	EPB Switch
F32	5A	Rain Light Sensor, Tyre Pressure Monitoring System
F33	10A	Sensing Diagnostic Module (Airbag)
F34	10A	Gateway
F35	20A	Sunshade Motor
F36	25A	Amplifier
F37	25A	Memory Seat Module
F38	-	-

Code	Specs	Function
F39	40A	Blower
F40-F43	-	-
F44	7.5A	Charging Plug Latch
F45	5A	Kick Sensor, Rear Driving Assistance Radar
F46	5A	Power Liftgate Control Module, Slim Air Vent Module
F47	5A	High Voltage PTC, Hot Pump Controller
F48	20A	Sunroof Motor
F49	5A	TBOX
F50	10A	Gateway
F51	5A	Shift Control Unit
F52	5A	Driver Door Switch Pack, AC Front Panel

Emergency Information

Code	Specs	Function
F53	10A	Pedestrian Alert Control Module
F54-F59	-	-

Emergency Information

Bulb Replacement

Bulb Specification

Bulb	Type
License Plate Lamps	W5W 5W
Front Threshold Lamps	W5W 5W
Glove Box Lamp	C10W 10W

Bulb Replacement

Before replacing any bulb, turn off the START/STOP Switch and lighting switch to avoid any possibility of a short circuit. When replacing the bulb, any actions should be gentle so as not to damage the lamp.

Note: Only replace bulbs with the same type and specification.

Note: If the bulb glass is scratched or contaminated, it may mean the bulb can not concentrate the light. Take care NOT to touch the glass with your fingers; If necessary, clean the glass with methylated spirits to remove fingerprints.

Consult an MG Authorised Repairer on specific replacement procedures.

Emergency Information

Glove Box Lamp

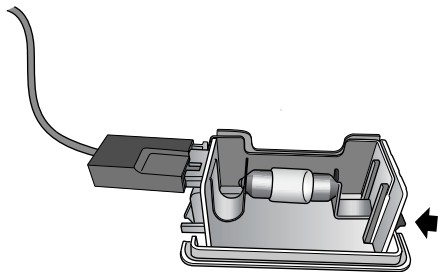

Reverse the process to install the new bulb and push the lamp back into position ensuring the retaining clips are fully in place.

- 1 Insert the flat-blade screwdriver into the slot at the narrow side (as arrowed in figure) of the lampshade , and carefully prize out the lamp assembly from its original position.
- 2 Whilst holding the bulb, push the bulb toward the sprung terminal (nearest the terminal connector), and lift out the bulb.

Maintenance

264 Maintenance

267 Bonnet

269 Front Compartment

271 Cooling System

273 Brake

275 Battery

277 High Voltage Battery Pack

279 Washer

281 Wipers

284 Tyre

290 Cleaning and Vehicle Care

Maintenance

Maintenance

Routine Servicing

The safety, reliability and performance of your car will depend partly on how well it is maintained. You must ensure that maintenance is carried out when required and according to the information contained in the "Service Schedule".

Servicing

For the next maintenance information, refer to "Information Center" or entertainment system related information in the "Instruments and Controls" section. After each maintenance, the MG Authorised Repairer which carries out the maintenance will reset the next maintenance information.

Note: *If the maintenance is not carried out (or the display is not reset by an MG Authorised Repairer after maintenance), the maintenance display will not be able to provide correct information.*

Service History

Ensure the MG Authorised Repairer registers the Service History after each service.

Brake Fluid Replacement

Replace the brake fluid according to the information contained in the "Service Schedule".

Note: *Brake fluid replacement will be an additional cost.*

Coolant Replacement

The coolant (anti-freeze and water solution) needs to be replaced according to the information contained in the "Service Schedule".

Note: *Coolant replacement will be an additional cost.*

Owner Maintenance



Any significant or sudden drop in fluid levels, or uneven tyre wear, should be reported without delay to MG Authorised Repairer.

In addition to the routine servicing referred to previously, a number of simple checks shall be carried out frequently by the owner. Advice is given on the pages that follow.

Daily Check

- Operation of lights, horn, wipers, washers and warning lamps.
- Operation of seat belts and brakes.
- Look for fluid deposits underneath the car that might indicate a leak.
- Check tyre appearance.

Weekly Check

- Coolant levels.
- Brake fluid level.
- Windscreen washer fluid level.
- Operate air conditioning.

Special Operating Conditions

If your car is frequently used in dusty conditions, or operated in extreme climates where sub-zero or very high ambient temperatures are normal, more frequent attention may need to be paid to servicing requirements. You need to carry out special maintenance operations (refer to Service Schedule) or contact an MG Authorised Repairer.

Safety in the Garage



Cooling fans may commence operating after the vehicle is switched off, and continue operating for a number of minutes. Keep clear of all fans while working in the front compartment.

If you need to carry out maintenance, observe the following safety precautions at all times:

- If the car has been driven recently, **DO NOT TOUCH** cooling system components until the drive motor has been fully cooled down.
- **DO NOT TOUCH** electrical leads or components when the START/STOP Switch is on.

Maintenance

- DO NOT work underneath the car with a wheel changing jack as the only means of support.
- Wear protective clothing and work gloves.
- Remove watches and jewelery before working in the front compartment.
- DO NOT allow tools or metal parts of the car to make contact with the battery leads or terminals.

Toxic Liquid

Fluids used in the vehicle are toxic and should not be swallowed or brought into contact with open wounds. These include: battery acid, coolant, brake fluid and windscreen washer fluid.

For your own safety, ALWAYS read and observe all instructions printed on labels and containers.

Bonnet

Opening the Bonnet



DO NOT drive when the bonnet is not closed or retained only by the safety catch.

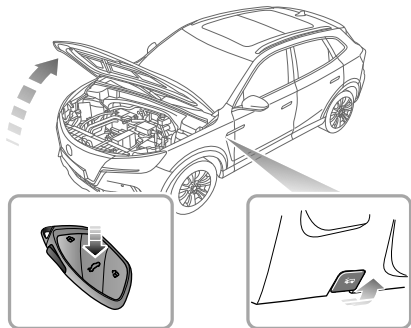

- 1 The bonnet can be unlocked using the following 2 methods:
 - Press and hold the bonnet button to unlock and release the bonnet.
 - Pull the bonnet release handle twice from the inside of the car.
- 2 Raise the bonnet to open it after the bonnet is unlocked.

Closing the Bonnet

Hold the bonnet using both hands and lower it to the catch position. Using the palms of your hands gently press down in the area of the latch fastener position of the bonnet until fully latched. By attempting to lift the front edge of the bonnet, check if the lock is fully engaged after closing the bonnet. If it is not fully engaged, please reopen the bonnet and repeat the closing action.

Bonnet Open Warning

If the bonnet is not fully engaged, the corresponding alarm icon will be displayed in the information message centre of the instrument pack.

Maintenance

IMPORTANT

- For safety reasons, the bonnet should be fully latched and secure when driving. Therefore every time the bonnet is opened, you must check after closing that the bonnet is securely latched, e.g. the bonnet edge is flush with the body of the car.
- You should stop the car immediately when safety permits and close the bonnet if it is not closed fully when driving.
- Beware of injury to hands while fully closing the bonnet with a downward force.

Maintenance

Front Compartment

2WD



While working in the front compartment, always observe the safety precautions listed under "Safety in the Garage". Refer to "Maintenance" in this section.

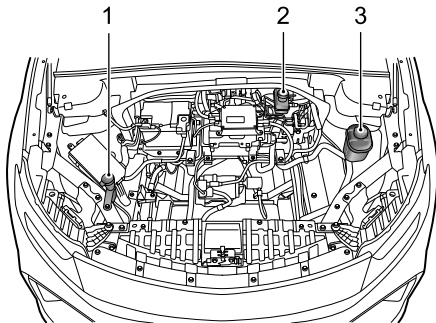

- 1 Washer fluid reservoir (black cap)
- 2 Brake fluid reservoir (black cap)
- 3 Coolant expansion box (black cap)

Maintenance

AWD



While working in the front compartment, always observe the safety precautions listed under "Safety in the Garage". Refer to "Maintenance" in this section.

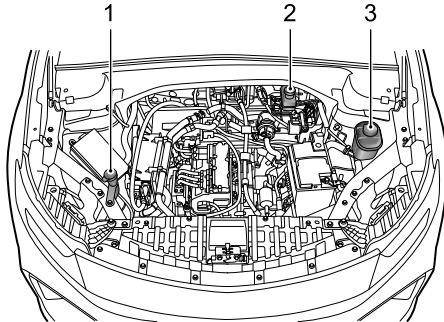

- 1 Washer fluid reservoir (black cap)
- 2 Brake fluid reservoir (black cap)
- 3 Coolant expansion box (black cap)

Maintenance

Cooling System



DO NOT remove the coolant pressure cap when the cooling system is hot - escaping steam or hot coolant could cause serious injury.

Note: Prevent coolant from coming into contact with the vehicle body when topping up. Coolant will damage paint.

If the coolant level falls appreciably during a short period, and you suspect that there may be a leak, please seek an Authorised Repairer for service.

Coolant Check and Top Up - EDS

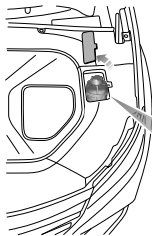

The cooling system should be checked weekly when the cooling system is cold and with the car resting on level ground. Open the bonnet, remove the coolant expansion tank trim cover and check the coolant level. If the coolant level is below the "MIN" mark, open the coolant expansion tank cap and top up coolant. The coolant level should not be higher than the "MAX" mark.

Coolant Check and Top Up - ESS

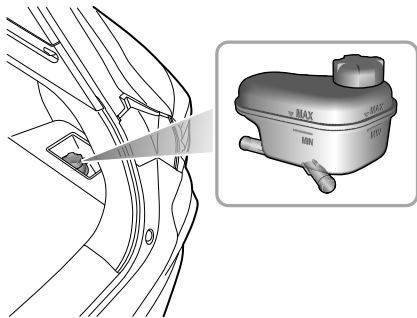

The cooling system should be checked weekly when the cooling system is cold and with the car resting on level ground. Open the tailgate, remove the coolant expansion tank trim cover and check the coolant level. If the coolant level is below the "MIN" mark, open the coolant expansion tank cap and top up coolant. The coolant level should not be higher than the "MAX" mark.

Coolant Specification



Coolant is poisonous and can be fatal if swallowed - keep coolant containers sealed and out of the reach of children. If accidental contact of coolant by children is suspected, seek medical assistance immediately.



Prevent the coolant from coming into contact with the skin or eyes. If this occurs, rinse immediately with plenty of water. If eyes are still red, painful or uncomfortable, seek medical attention immediately.

Please use the coolant (mix of water and antifreeze) which is recommended and certified. Please refer to 'Recommended Fluids and Capacities' in the "Technical Data" section.

Note: The addition of corrosion inhibitors or other additives to the cooling system of this car may severely disrupt the efficiency of the system and cause parts damage. For cooling system issues please consult an Authorised Repairer.

Brake

Brake Pads



DO NOT rest your foot on the brake pedal while driving; this may overheat the brakes, reduce their efficiency and cause excessive wear.

For the first 1500 km, you should avoid situations where heavy braking is required.

Remember that regular servicing is vital to ensure that all the brake components are examined for wear at the correct intervals, and replaced when required to ensure long term safety and optimum performance during the intervals outlined in the Service Schedule.

The vehicle needs to be run in for 800 km after brake pad or disc replacement.

Brake Fluid Check and Top Up



Brake fluid is highly toxic. Keep containers sealed and out of the reach of children. If accidental contact of brake fluid is suspected, seek medical attention immediately.



Prevent brake fluid from coming into contact with the skin or eyes. If this occurs, rinse immediately with plenty of water. If eyes are still red, in pain or uncomfortable, seek medical attention immediately.

The brake fluid level should be checked weekly when the system is cold and with the car on level ground.

The brake fluid level can be seen through the reservoir and should be maintained between the "MAX" and "MIN" marks.

Note: Do not allow the brake fluid level to drop below the "MIN" mark or rise above the "MAX" mark.

Maintenance

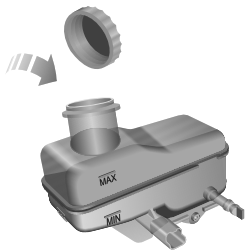

Note: Brake fluid will damage painted surfaces. If you accidentally spill the brake fluid on the painted surface, soak up any spillage with an absorbent cloth immediately and wash the area with water or car shampoo.

Brake Fluid Specification

Use the brake fluid recommended and approved by the manufacturer. Refer to "Recommended Fluids and Capacities" in the "Technical Data" section.

IMPORTANT
Replace brake fluid regularly according to the Service Schedule.

Battery

Battery Maintenance



DO NOT leave electric components switched on when the vehicle is not in **READY** mode, otherwise the battery may become flat, resulting in the failure to start the vehicle and the reduction of battery life.



Always store batteries upright, tilting may allow the corrosive substances contained within the battery to leak out.



Never attempt to dismantle a battery, they are sealed units.

The battery is located in the front compartment and is maintenance-free, therefore there is no need to refill fluid.

According to the current load condition and battery status, the system may limit the power of some electrical appliances. Please place the vehicle in **READY** mode as soon as possible to charge the battery.

Note: It is recommended to set the power mode to **READY** for half an hour every week to help extend the service life of the battery. If the vehicle is stored for a long time, remove the negative terminal from the battery. Make sure that the vehicle power system has been turned off before connecting or disconnecting the negative terminal.

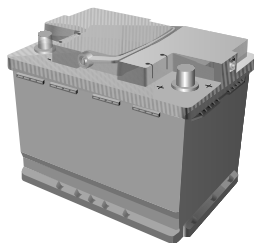

Battery Replacement



The battery contains sulphuric acid, which is corrosive.

Please go to an MG Authorised Repairer to remove and refit the battery. Only fit a replacement battery of the same type and specification as the original to maintain the correct vehicle functionality.



The used battery should not be discarded at will, for it is harmful to the environment. It must be recycled by professional institutes. Please consult an MG Authorised Repairer for more details.

High Voltage Battery Pack

Precautions and restricted conditions for use of battery



If the vehicle is not going to be used, parked, or stored for a long time it is necessary to charge the vehicle at least once every 3 months. During this time, the High Voltage battery state of charge should not be allowed to drop below 50%.



*If the battery is in a low state of charge and the instrument pack displays no valid driving range, the vehicle **MUST NOT** be left in a stored state for more than 7 days without being charged to above 50%.*



Failure to follow these guidelines will result in HV battery damage and invalidate the warranty.



DO NOT attempt to dismantle the battery pack or any High Voltage components - THESE ARE DANGEROUS. Any signs of dismantling or damage caused by attempts to dismantle will invalidate the warranty.

- 1 DO NOT park the vehicle in conditions where the ambient temperature exceeds 45°C for more than 15 days. This will effect the performance and service life of the high voltage battery.
- 2 To maintain or improve the service life of the high voltage battery, it is recommended that you use a slow charging method wherever possible, rapid charging should only be used for long distance journeys or emergencies.
- 3 It is recommended using the vehicle at least once a month.

Where possible it is recommended that you carry out a slow charging (equalisation charging) every month to extend the service life of high-voltage battery pack. The battery management system will monitor the status of the high voltage battery pack. After monitoring for a period of time, if an equalisation charge has not been

Maintenance

carried out for some time the message centre in the instrument pack will display 'Please slow charging the car to balance the battery'. At this time you must carry out an equalisation charge. For operation mode, please refer to 'Equalisation Charging' in 'Starting & Driving' section.

- 4 In the event of an accident, damage to the high voltage battery or any of its related components, or any repairs made to the high voltage system the car must be inspected by qualified personnel at an MG Authorised Repairer.
- 5 In the event of any accident or body repairs being required please consult the qualified personnel at an MG Authorised Repairer. The repair may require high voltage battery isolation or specialist HV component removal.

IMPORTANT

Only fully trained and qualified personnel are allowed to work on the high voltage systems and components of this vehicle. Any disassembly of such systems or components is strictly prohibited.

Washer

Washer Fluid Check and Top Up



When filling the washer fluid, DO NOT let the washer fluid spill on parts around the engine or electric transmission or on the paint surface of vehicle body. In case the washer fluid is spilled on hands or other parts of the body, please immediately wash with clean water.

Check the washer fluid level regularly. When the level of washer fluid is low, please top up the washer fluid as instructed. Please use the washer fluid recommended and certified by the manufacturer. Refer to 'Recommended Fluids and Capacities' in "Technical Data" chapter.

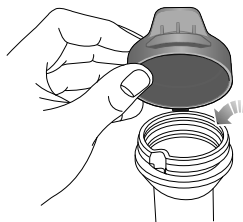

Note: *DO NOT use an anti-freeze or vinegar/water solution in the washer reservoir - anti-freeze will damage paintwork while vinegar will damage the washer pump.*

Maintenance

IMPORTANT

- Use the washer fluid recommended and certified by the manufacturer. Misuse of washer fluid in winter may cause damage to the washer motor due to freezing.
- Using the washer switch when there is no washer fluid may cause damage to the washer motor.
- Operating the wipers when the windscreen is dry and there is no washer fluid may cause damage to the windscreen and wipers. Please spray the washer fluid and start the wipers when there is adequate washer fluid.

Washer Nozzles

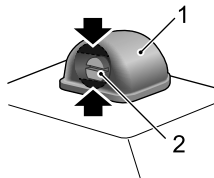

Operate the washers periodically to check that the nozzles are clear and properly directed.

The windscreen washer nozzles are configured during production. To adjust the windscreen washer nozzle, you can insert a small flat-bladed screwdriver in the upper and bottom gaps (as indicated by the arrow) between the housing (1) and the nozzle (2) and turn downward or upward slightly to adjust to the appropriate spray angle.

If the nozzle is obstructed, insert a needle or thin metal wire into the hole to remove the obstruction.

Maintenance

Wipers

Wiper Blades

IMPORTANT

- Grease, silicon and petroleum products impair the blade's wiping capability. Clean the wiper blades in warm soapy water, and check their status periodically.
- Clean the windscreen frequently. DO NOT use wipers to remove stubborn or ingrained dirt. It will reduce their effect and their life span.
- If signs of hardness or cracking in the rubber are found, or if the wipers leave streaks or unwiped areas on the screen, then the wiper blades should be replaced.
- Clean the windscreen regularly with an approved glass cleaner and ensure the windscreen is thoroughly cleaned before fitting replacement wiper blades.
- Only fit replacement wiper blades that are identical to the original specification.
- Clean ice and snow from the wipers and ensure they are not frozen or otherwise sticking to the windscreen before attempting to operate them.

Maintenance

Replacing Front Windscreen Wiper Blades

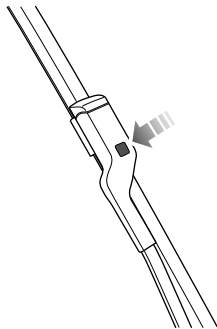

- 1 With the bonnet in a closed state, and within 20 seconds of setting the START/STOP Switch to the OFF position, operate the wiper stalk switch by pressing down and release. The wipers will enter the 'service position' and stop on the windscreen.
- 2 Lift the wiper arm away from the windscreen.
- 3 Press the button on the wiper arm (as illustrated), and pull the upper end of the wiper blade outward to disengage from the wiper arm.
- 4 Unhook the blade from the wiper arm and discard.
- 5 Place the new wiper into the slot of the wiper arm.
- 6 Push the wiper blade towards the arm until the wiper blade is engaged.
- 7 Check whether the wiper blade is fitted correctly to the arm before positioning on the windscreen.
- 8 Operate the wiper stalk switch by pressing down again and release, or set the START/STOP Switch to ON. The wiper will exit the service mode and automatically return to its original position

Replacing Rear Window Wiper Blades

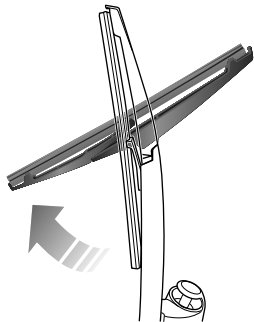

- 1 Lift the wiper arm away from the windscreen.
- 2 Rotate the wiper blade as shown in the figure to remove it from the wiper arm and discard.
- 3 Fit the new wiper blade into the slot of the wiper arm. Ensure the wipers blade is properly secured on the wiper arm.
- 4 Place the wiper assembly back on the rear window.

Maintenance

Tyre

Overview

- Take extra care when using new tyres for the first 500km.
- Regularly check tyres for signs of damage. DO NOT remove foreign objects such as screws or nails from the tyre. If a tyre shows any signs of damage, please ensure it is inspected by a reputable tyre fitter for advice.
- The valve dust cap must be fitted to prevent dust from entering the valve.
- If the tyre is to be removed, always mark the tyre/wheel orientation to ensure correct reinstallation.
- Store the removed wheel or tyre in a cool, dry and dark place.

New Tyres

New tyres may not have the same adhesion properties of the old tyres. Please break them in at a moderate speed using a careful driving style for the first 500km. This action could benefit tyre life.

The damage of a tyre or rim may happen unnoticed. If abnormal vibration or deviation is experienced, that means

the tyre may have been damaged. If you suspect that a tyre is damaged, please slow down immediately, and stop your vehicle to check the tyre for damage. If you can't see the damage from the outside, continue driving the vehicle slowly to the nearest MG Authorised Repairer for inspection and service.

Directional Tyres

Directional tyres are marked with 'direction of rotation' (DOR). To maintain handling characteristics, tyre performance, low road noise and extend tyre life, tyres must always be fitted with indication arrow showing the correct 'DOR'.

Tyre Life

Correct tyre pressure and moderate driving style can extend tyre life. Recommendations:

- When the vehicle is to be parked for a long time, the vehicle should be moved at least once every two weeks to prevent permanent deformation of the tyres due to long-term stress;
- Check the tyre pressure at least once a month, and it should be carried out when the tyre is cold;

- Avoid cornering at excessive speeds;
- Check tyres frequently for abnormal wear.

The following factors affect the tyre life:

Tyre Pressure

Incorrect tyre pressures can result in poor driving characteristics and a shortened tyre life. Tyre pressures should be checked at least once a month, and once prior to each long-distance journey.

Driving Style

Excessively harsh acceleration and braking whilst cornering will reduce tyre life.

Wheel Dynamic Balance

Every new vehicle leaves the factory having had the wheels dynamically balanced. Out of balance wheels may be due to many factors. If wheels are out of balance, shaking or vibration of the steering mechanism may occur and the tyres may start to wear excessively. It is important to restore wheel balance as quick as possible. Each wheel should be rebalanced after installing a new tyre or having a tyre repair.

Wheel Alignment

Incorrect wheel alignment can cause excessive tyre wear and affect vehicle safety. If the tyres show signs of abnormal wear, check the wheel alignment and seek advice from an MG Authorised repairer.

Maintenance

Caring for your Tyres



DEFECTIVE TYRES ARE EXTREMELY DANGEROUS! DO NOT drive if any tyre is damaged, excessively worn, or incorrectly inflated.

Always drive with consideration for the condition of the tyres, and regularly inspect the tread and side walls for any sign of distortion (bulges), cuts or wear.



If possible, protect tyres from contamination by oil, grease and fuel.

Tyre Pressure



Before a long distance journey, the tyre pressures should be checked.

Check the pressures (including the spare wheel if fitted) at least every month. Carry out pressure checks when the tyres are cold.

If it is necessary to check the tyres when they are warm, you should expect the pressures to have increased by 30 ~

40 kPa. In this circumstance, NEVER let air out of the tyres in order to match the recommended pressures (cold) in the technical data.

Valves

Keep the valve caps firmly secured to prevent dirt from entering the valve. Check the valve for leaks (listen for a tell-tale hissing) when you check the tyre pressure.

Punctured Tyres

Your vehicle is fitted with tyres which may not leak if penetrated by a sharp object, provided the object remains in the tyre. If you are aware of this occurring, reduce speed immediately and drive with caution until the spare wheel can be fitted, or repairs undertaken.

Note: If the sidewall of the tyre is damaged or distorted, replace the tyre immediately. Do not attempt a repair.

Tyre Wear Indicators

Tyres fitted as original equipment have wear indicators moulded into the tread pattern at several points around the

Maintenance

circumference. When the tread has worn down to 1.6mm the indicators will come to the surface of the tread pattern, producing the effect of a continuous band of rubber across the width of the tyre.

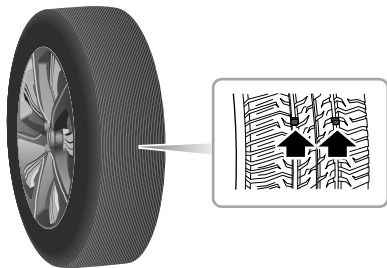

IMPORTANT

A tyre **MUST** be replaced as soon as a wear indicator becomes visible. Otherwise there may be a risk of accidents.

Replacement of Tyres



When replacing tyres, it is strongly recommended that the new tyres are of the same specification as the original tyres. Alternative tyres of a different specification, or unqualified tyres may adversely affect the vehicle's driving performance and safety. In order to maintain comfort and safety, it is recommended to seek advice from an MG Authorised Repairer.



***DO NOT** replace the tyres with tyres of any other type.*

Always have replacement wheels and tyres balanced before use.

Tyre Rotation

It is recommended that you swap wheels from side to side or front to rear at irregular intervals in order to equalise tyre wear.

Maintenance

Note: Tyre/wheel rotation should be carried out on the vehicle with the same front/rear wheel specifications. When the front/rear wheel specifications of the vehicle are not consistent, it is not recommended to carry out the tyre rotation.

In cases of even front tyre wear, it is recommended to exchange the front and rear wheels as shown in the figure. This can equalise tyre wear, extend tyre life, and uniform tyre fatigue.

When a certain amount of wear occurs on the surface of the tyre, it is advantageous to exchange the wheels diagonally.

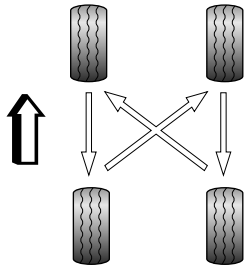

Note: Directional tyres (identified by the arrow on the tyre sidewall) CANNOT be swapped diagonally or from side to side.

Note: After any tyre/wheel rotation, it will be necessary to drive the vehicle at a speed of 40km/h for about 10 minutes to correctly indicate the tyre pressure value at the corresponding position.

Tyre/Snow Chains

Unsuitable tyre/snow chains may damage the tyres, wheels, suspension, brakes or bodywork of your vehicle.

Please pay attention to the following requirements during usage:

- The tyre/snow chains can only be fitted on the drive wheels;
- The thickness of tyre/snow chains must not exceed 15mm;
- Please always observe the installation and tension instructions for the tyre/snow chains, as well as the speed limits of different roads;
- Do not drive faster than 50km/h;
- To avoid the tyre damage and excessive wear of the tyre/snow chains, the tyre/snow chains must be removed while driving on the road without snow.

For this vehicle, the only specification of wheels and tyres that will support tyre/snow chains are as follows:

Wheel rim size: 7.5J×18

Tyre size: 235/50 R18

Note: If you often drive on snow covered and icy roads, it is recommended to use winter tyres. Please consult an MG Authorised Repairer for details.

Maintenance

Cleaning and Vehicle Care



Observe all safety precautions on cleaning products; Do Not drink fluids and keep them away from the eyes.

Exterior

Washing Your Car



Some high pressure cleaning systems will penetrate door, window and sunroof seals, and damage lock mechanisms. DO NOT aim water jets directly at components that might be easily damaged. Ensure the vehicle power system is OFF when washing your car.



Do not clean the front compartment with high pressure water since it may damage the electrical system of the vehicle.

In order to preserve the paint finish on your car, please observe the following care points:

- DO NOT use hot water to wash the car.
- DO NOT use detergents or washing up liquid.

- In hot weather, DO NOT wash the car in direct sunlight.
- When using a hose, DO NOT aim the water directly at window, door or sunroof seals, or through wheel apertures onto the brake components.

If the car is particularly dirty, use a hose to flush grime and grit from the bodywork, prior to washing. Then, wash the car using cold or lukewarm water containing a good quality wash and wax shampoo. Always use plenty of water to ensure that grit is flushed from the surface and not ground into the paintwork. After washing, rinse the bodywork with clean water and dry off with a chamois leather.

Cleaning the underside

Note: *DO NOT use a high pressure hose to clean the front compartment – damage to the car's electronic systems may occur.*

From time to time, but particularly during winter months when salt has been used on the roads, use a hose to wash the underside of the car. Flush away accumulations of mud and thoroughly clean those areas where debris can easily collect (wheel arches and panel seams, for example).

Maintenance

IMPORTANT

- Avoid cleaning the vehicle in direct sunlight.
- When cleaning the vehicle in winter avoid spraying water directly onto door locks and panel gaps due to risk of icing.
- Do not use rough sponges or cloth to clean the car, this will damage the paintwork finish.
- When cleaning the headlamps do not use a dry cloth or sponge, use only warm soapy water.

Cleaning with a High Pressure Cleaner

Note: Always read the manufacturers operating instructions.

When using high pressure washers, always ensure there is adequate distance between the spray nozzle and any soft materials, decals or rubber seals.

Note: **DO NOT direct the pressure washer nozzle directly toward the high voltage charging point or high voltage battery connections on the underside of the vehicle.**

IMPORTANT

- Please pay attention to the operating instructions of high pressure cleaner.
- High pressure cleaners should not be closely directed at soft parts of the vehicle.

Removing tar spots

Use white spirit to remove tar spots and stubborn grease stains from the paintwork. Then wash the area immediately with soapy water to remove all traces of the spirit.

Body Protection

After washing, examine the paintwork for damage. If the damage has revealed bare metal, use a colored primer first, then apply the correct colour base coat and finish off with a lacquer pencil, if appropriate. Carry out this treatment after washing but before polishing or waxing. More extensive damage to paint or bodywork must be repaired in accordance with the manufacturer's recommendations. Failure to do this will invalidate the Anti-Corrosion Warranty. If in doubt, ask your MG Authorised Repairer.

Maintenance

Polishing the Paintwork



DO NOT use car polish containing coarse abrasives – these will remove the paint film and damage the gloss finish.

Occasionally treat the paint surface with an approved polish containing the following properties:

- Very mild abrasives to remove surface contamination without removing or damaging the paint.
- Filling compounds that will fill scratches and reduce their visibility.
- Wax to provide a protective coating between the paint and the elements.

Note: If possible, avoid applying polish or wax products to window glass and rubber seals.

Wiper Blades

Wash in warm soapy water. DO NOT use spirit or solvent based cleaners.

Windows and Mirrors

Regularly clean all windows, inside and out, using an approved glass cleaner.

Windscreen: In particular, clean the outside of the screen with glass cleaner after washing the car with wash and wax products, and before fitting new wiper blades.

Rear screen: Clean the inside with a soft cloth, using a side to side motion to avoid damaging the heating elements.

Note: DO NOT scrape or use abrasive cleaners on the inside of the rear screen – this will damage the heating elements.

Mirrors: Wash with soapy water. Use a plastic scraper to remove ice. DO NOT use abrasive cleaning compounds or metal scraper.

Plastic Components

Any plastic components should be cleaned using conventional cleaning methods and not be treated with abrasive materials.

Maintenance

Paint Damage

Any paint damage or stonechips should be treated with suitable paint/lacquer materials immediately to avoid invalidating the Anti Corrosion Warranty.

Weather Strips and Rubber Seals

Any weather strips or rubber aperture seals should be treated with suitable materials (silica gel) if they are cleaned using strong detergents, this should avoid any sticking and maintain the service life of the seal.

Wheels



When cleaning the wheels any materials or water that contact the brake disc directly may effect braking efficiency.

In order to ensure the wheels are kept in optimum condition they should be cleaned regularly.

Only use a recommended non-acidic propriety wheel cleaner. Always read the instructions on the product.

Cleaning the Interior

Plastic materials

Clean plastic-faced materials with diluted upholstery cleaner, then wipe with a damp cloth.

Note: DO NOT polish dashboard components – these should remain non-reflective.

Carpet and fabrics

Clean with diluted upholstery cleaner - test a concealed area first.

Leather

Clean leather trim with warm water and a non-detergent soap. Dry and polish the leather with a dry, clean, lint-free cloth.

Note: DO NOT use petrol, detergents, furniture creams or polishes as cleaning agents.

Instrument Pack, Audio and Navigation Display

Clean with a dry cloth only. DO NOT use cleaning fluids or sprays.

Airbag Module Covers



DO NOT allow these areas to be flooded with liquid and DO NOT use petrol, detergent, furniture cream or polishes.

To protect damage to the airbag SRS, the following areas should be cleaned sparingly with a damp cloth and upholstery cleaner **ONLY**:

- Steering wheel centre pad.
- Area of dashboard containing the passenger airbag.
- Area of roof lining and front pillar finishers which enclose the side head impact protection modules.

Seat Belts



DO NOT use bleaches, dyes or cleaning solvents on seat belts.

Extend the belts, then use warm water and a non-detergent soap to clean. Allow the belts to dry naturally; **DO NOT** retract them or use the car until they are completely dry.

Technical Data

296 Technical Data Dimensions

298 Weights

300 Parameters of Traction Motor

*301 Recommended Fluids and
Capacities*

302 Wheel Alignment (Unladen)

302 Wheels and Tyres

302 Tyre Pressure (Cold)

Technical Data

Technical Data Dimensions

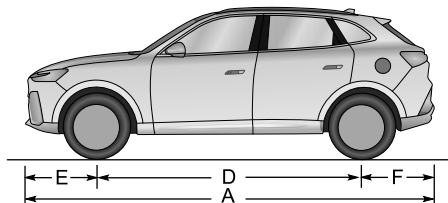
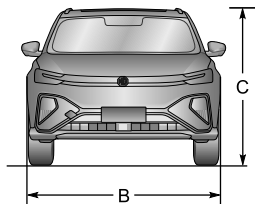

Item, Units	Parameter	
	Option 1	Option 2
Overall length A, mm	4674	
Overall width B, mm	1919	
Overall height C (unladen), mm	1613 (with body) 1618 (with shark fin)	
Wheelbase D, mm	2800	

Technical Data

Item, Units	Parameter	
	Option 1	Option 2
Front Overhang E, mm	953	
Rear Overhang F, mm	921	
Front wheel track, mm	1616	
Rear wheel track, mm	1625	
Minimum ground clearance (laden), mm	133.9	131.9

Note: Vehicle length not including the license plate.

Note: Rearview mirrors and the deformed portion of tyre wall directly above the touchdown point are not included in the total width.

Technical Data

Weights

Item, Units	Parameter	
	Option 1	Option 2
Person in cab, person	5	
Unladen vehicle weight (kerb), kg	1810	1920
Gross vehicle weight, kg	2288	2373
Unladen front axle weight, kg	816	928
Unladen rear axle weight, kg	994	992
Laden front axle weight, kg	963	1049
Laden rear axle weight, kg	1325	1324

Technical Data

Towing Weights

Item, Units	Parameters
Towing limit unbraked, kg	750

Note: When towing a trailer, the vehicle speed **MUST** not exceed 100km/h.

Note: Prior to towing a trailer, please check the rear tyre pressures, inflate to at least 20kPa (0.2bar) above the recommended pressure - **DO NOT** allow the tyre pressure to exceed 300kPa (3.0 bar), this can be dangerous.

Technical Data

Parameters of Traction Motor

Item, Units	Parameter Values	
	Front/Rear Left Motor	Rear Right Motor
Traction motor type	Three-phase permanent magnet synchronous motor	
Continuous Power/Maximum Net Power, kW	40/80	25/52
Rated Torque/Peak Torque, Nm	125/255	70/155
Rated Speed/Maximum Speed, rpm	3100/10000	3500/10000
Winding Type	Y	
Waterproof Grade	IP67	

Technical Data

Recommended Fluids and Capacities

Name	Grade	Capacity	
		2WD	4WD
Electric drive transmission coolant, L	Glycol (OAT)	9	10.8
High-voltage battery pack coolant, L		5	
Front electric drive transmission oil, L	Castrol BOT 35I LV	-	0.85
Rear electric drive transmission oil, L		0.95	
Brake fluid, L	DOT 4	0.8	
Windshield detergent, L	QX35	2.5	
Air conditioning refrigerant, g	R1234yf	980±20	

Technical Data

Wheel Alignment (Unladen)

	Item	Parameter
Front	Camber	$-0^{\circ}20' \pm 45'$
	Castor	$5^{\circ}48' \pm 45'$
	Toe in (Total)	$0^{\circ}6' \pm 12'$
	Kingpin Inclination	$13^{\circ}28' \pm 45'$
Rear	Camber	$-60' \pm 45'$
	Toe in (Total)	$0^{\circ}12' \pm 12'$

Tyre Pressure (Cold)

Wheels	Unladen
Front	280kPa/2.8bar/41psi
Rear	280kPa/2.8bar/41psi

Wheels and Tyres

Wheel size	7.5J×18	8.5J×19
Tyre size	Front 215/55 R18	235/45 R19
	Rear 235/50 R18	